

1506 and 1507

Industrial PC/AT[®] Node Box
Systems

User Manual

Revision	Description	Date
A	Manual Released	9/03

Part Number 143095 (A)

Trademark Information

Brand or product names are trademarks or registered trademarks of their respective owners. Intel and Pentium are registered trademarks and Celeron is a trademark of Intel Corporation. Windows, Windows NT, and Windows XP are registered trademarks of Microsoft Corporation in the U.S. and in other countries.

Copyright Information

This document is copyrighted by Xycom Automation Incorporated (Xycom Automation) and shall not be reproduced or copied without expressed written authorization from Xycom Automation.

The information contained within this document is subject to change without notice. Xycom Automation does not guarantee the accuracy of the information.

United States FCC Part 15, Subpart B, Class A EMI Compliance Statement:

NOTE: This equipment has been tested and found to comply with the limits for a Class A digital device, pursuant to part 15 of the FCC Rules. These limits are designed to provide reasonable protection against harmful interference when the equipment is operated in a commercial environment. This equipment generates, uses, and can radiate radio frequency energy and, if not installed and used in accordance with the instruction manual, may cause harmful interference to radio communications. Operation of this equipment in a residential area is likely to cause harmful interference in which case the user will be required to correct the interference at the user's expense.

For European Users – WARNING:

This is a Class A product. In a domestic environment this product may cause radio interference in which case the user may be required to take adequate measures.

INSTALLATION: Electromagnetic Compatibility WARNING:

The connection of non-shielded equipment interface cables to this equipment will invalidate FCC EMI and European Union EMC compliance and may result in electromagnetic interference and/or susceptibility levels which are in violation of regulations applying to the legal operation of this device. It is the responsibility of the system integrator and/or user to apply the following directions relating to installation and configuration:

All interface cables must include shielded cables. Braid/foil type shields are recommended. Communication cable connectors must be metal, ideally zinc die-cast backshell types, and provide 360-degree protection about the interface wires. The cable shield braid must be terminated directly to the metal connector shell; ground drain wires alone are not adequate.

Protective measures for power and interface cables as described within this manual must be applied. Do not leave cables connected to unused interfaces or disconnected at one end. Changes or modifications to this device not expressly approved by the manufacturer could void the user's authority to operate the equipment.

EMC compliance is, in part, a function of PCB design. Third party add-on AT/XT peripheral PCB assemblies installed within this apparatus may void EMC compliance. FCC/CE compliant PCB assemblies should always be used where possible. XYCOM AUTOMATION can accept no responsibility for the EMC performance of this apparatus after system integrator/user installation of PCB assemblies not manufactured and/or expressly tested and approved for compliance by XYCOM AUTOMATION. It is the responsibility of the system integrator/user to ensure that installation and operation of such devices does not void EMC compliance.

Table of Contents

CHAPTER 1 – INTRODUCTION	1
PRODUCT OVERVIEW	1
<i>Standard Features</i>	1
<i>Optional Features</i>	2
UNPACKING THE SYSTEM	2
QUICK STARTUP	3
CHAPTER 2 – INSTALLATION.....	4
MOUNTING PLATES	4
1506 Mounting Plate	4
1507 Mounting Plate	5
BACK PANELS AND POWER PANELS	6
1506 Back Panel and Power Panel	6
1507 Back Panel and Power Panel	7
1506 AND 1507 I/O PANEL	8
PREPARING THE SYSTEM	10
INSTALLING INTERNAL HARDWARE OPTIONS	10
<i>DRAM and Additional DRAM Dual Inline Memory Modules (DIMMs)</i>	11
<i>PC/AT® and PCI Boards</i>	11
INSTALLING THE SYSTEM WITHIN AN ENCLOSURE	12
MOUNTING CONSIDERATIONS	12
<i>System Power</i>	13
<i>Excessive Heat</i>	13
<i>Electrical Noise</i>	14
<i>Line Voltage Variation</i>	14
AC POWER CABLE	14
1506 POWER SUPPLY	16
1507 POWER SUPPLY	16
MOUNTING THE UNIT	17
SYSTEM MOUNTING DIMENSIONS	18
1506 Vertical Mounting	18
1506 Horizontal Mounting	19
1507 Vertical Mounting	20
1507 Horizontal Mounting	21
HAZARDOUS LOCATIONS INSTALLATION	21
SAFETY AGENCY APPROVAL.....	22
<i>Definitions</i>	23
<i>Class I Locations</i>	23
<i>Class II Locations</i>	24
<i>Division 1 Locations</i>	24
<i>Division 2 Locations</i>	24
<i>Groups</i>	25
ENCLOSURES	25
POWER SWITCH.....	25
CABLE CONNECTIONS.....	26
<i>Communication Cable Interface</i>	26
OPERATION AND MAINTENANCE	26
CHAPTER 3 – MAINTENANCE	28
GENERAL PREVENTIVE MAINTENANCE	28
<i>Fuse Replacement</i>	28
<i>Fan Filter Replacement</i>	28
RECOMMENDED HARD DRIVE PREVENTIVE MAINTENANCE	29
PRODUCT REPAIR PROGRAM / RETURNING A UNIT TO XYCOM AUTOMATION	30
CHAPTER 4 – TROUBLESHOOTING.....	31
DIAGNOSTIC TESTING	31

RUNNING THE TESTS	33
REINSTALLING OPERATING SYSTEMS	34
MS-DOS® Reinstallation	34
Windows® 98 Reinstallation	34
Windows® 2000 Reinstallation	35
Windows NT® Reinstallation	35
Windows XP® Reinstallation	35
INSTALLING DRIVERS	36
Video Drivers	36
Video Expansion	36
Miscellaneous Drivers	37
APPENDIX A – TECHNICAL SPECIFICATIONS.....	38
HARDWARE SPECIFICATIONS	38
ENVIRONMENTAL SPECIFICATIONS	39
APPENDIX B – AC MODEL BLOCK DIAGRAM.....	40
APPENDIX C – PINOUTS	41
KEYBOARD PORT CONNECTOR	41
MOUSE PORT CONNECTOR	41
DUAL USB CONNECTOR (USB1)	42
PARALLEL PORT CONNECTOR (LPT1).....	42
SERIAL PORT CONNECTORS.....	42
COM1.....	43
COM2.....	43
VGA CONNECTOR	44
APPENDIX D – AIM3 CONTROLLER JUMPERS.....	45
INDEX	46

Chapter 1 – Introduction

Product Overview

The 1506 and 1507 Node Box Industrial PCs offer a powerful, compact package for the factory floor and other harsh environments. These node box industrial PCs feature an open architecture to meet a wide variety of applications that require both a powerful PC and a durable industrial enclosure. The systems integrate a computer card cage, mass storage, and power supply in a truly industrial form.

The processor board combines all the functions of a complete PC/AT[®] compatible computer on a single industrially hardened circuit board. Refer to the AIM3 CPU manual for more information on processor and hardware features.

Standard Features

The 1506 and 1507 units come standard with the following features:

- Wall or shelf mountable
- Flash BIOS
- Intel[®] Socket 370 Celeron[®] or Pentium[®] III options up to 1.26GHz
- 100MHz or 133MHz front side bus depending on the processor type
- 1506 – Four AT bus expansion slots
 - One ½ length PCI
 - One ¾ length PCI
 - One ¾ length ISA
 - One ¾ length PCI or ISA slot
- 1507 – Four AT bus expansion slots
 - One ½ length PCI
 - One full length PCI
 - One full length ISA
 - One full length PCI or ISA slot
- AGP graphics with base 4 MB system RAM
 - Automatically shares up to 32 MB with system RAM
- Up to 512 MB DRAM
- 20 GB removable hard drive
- Floppy drive
- CD-ROM

- IBM[®] PS/2[®] keyboard port and mouse port
- Two serial COM ports
 - RS-232
 - RS-232 or RS-485
- Parallel port and VGA port
- Two USB 1.1 ports
- MS-DOS[®] operating system
- UL Listed for use in Class I, Division 2 hazardous locations

Optional Features

Following are optional available features of the 1506 and 1507:

- Higher capacity IDE hard drives and solid state drives
- Various processor speeds
- Preinstalled Microsoft[®] Windows[®] 98, or Windows NT[®], or Windows[®] 2000, or Windows XP[®] Professional
- 9000-USB, USB floppy (requires Windows 98, 2000, or XP)
- Secondary IDE Drive Options (choice of one):
 - Externally accessible CompactFlash[™] options up to 512MB
 - 2.5" Dual hard drives
 - External Drive bay connector for 9000-XBAY (9000-XBAY sold separately)

Unpacking the System

When you remove the system from its shipping container, verify that you have the parts listed below. Save the box and inner wrapping in the event you need to reship the unit.

- 1506 or 1507 unit
- Documentation kit, which includes:
 - Power connector
 - Fourteen 10-32 hex nuts (2 spares)
 - Cable clamp and screw (for strain relief of power cord)
 - Documentation and Support Library CD-ROM
 - Operating System Recovery Media or retail operating system (CD-ROM)
 - Mounting hardware

Quick Startup

This section gives you the steps to get the system up and running without explaining the capabilities and options.

Warning

Remove power from the unit and disconnect the power cord before making any adjustments to the inside or outside of the computer.

Warning

For hazardous locations installation, review “Hazardous Locations Installation” in Chapter 2 before startup.

To prepare the system for use, perform the following steps.

1. Attach optional keyboard to the keyboard port.
2. Attach other optional equipment following the instructions in Chapter 2.
3. Check the 115/230 VAC selector switch on the power supply to see that it is set appropriately (applies only to 1506 units).
4. Attach the power cord from the power receptacle to a properly grounded 115/230 VAC, 50-60 Hz outlet. (See Chapter 2, *AC Power Cable*.)
5. Turn on power to the unit (via an outlet power switch if applicable). The system will boot up into the operating system.
6. If not pre-installed, install application software via the floppy, the CD-ROM, or a network.

Chapter 2 – Installation

This chapter illustrates the installation of, and the options for the 1506 and 1507 Node Boxes. The figures on the next several pages show the internal and external components of the units to help you locate features relevant to installation.

Mounting Plates

1506 Mounting Plate

The 1506 mounting plate protects the system's interior when the system is properly mounted (refer to the *Mounting Considerations* and *Mounting Instructions* sections later in this chapter).

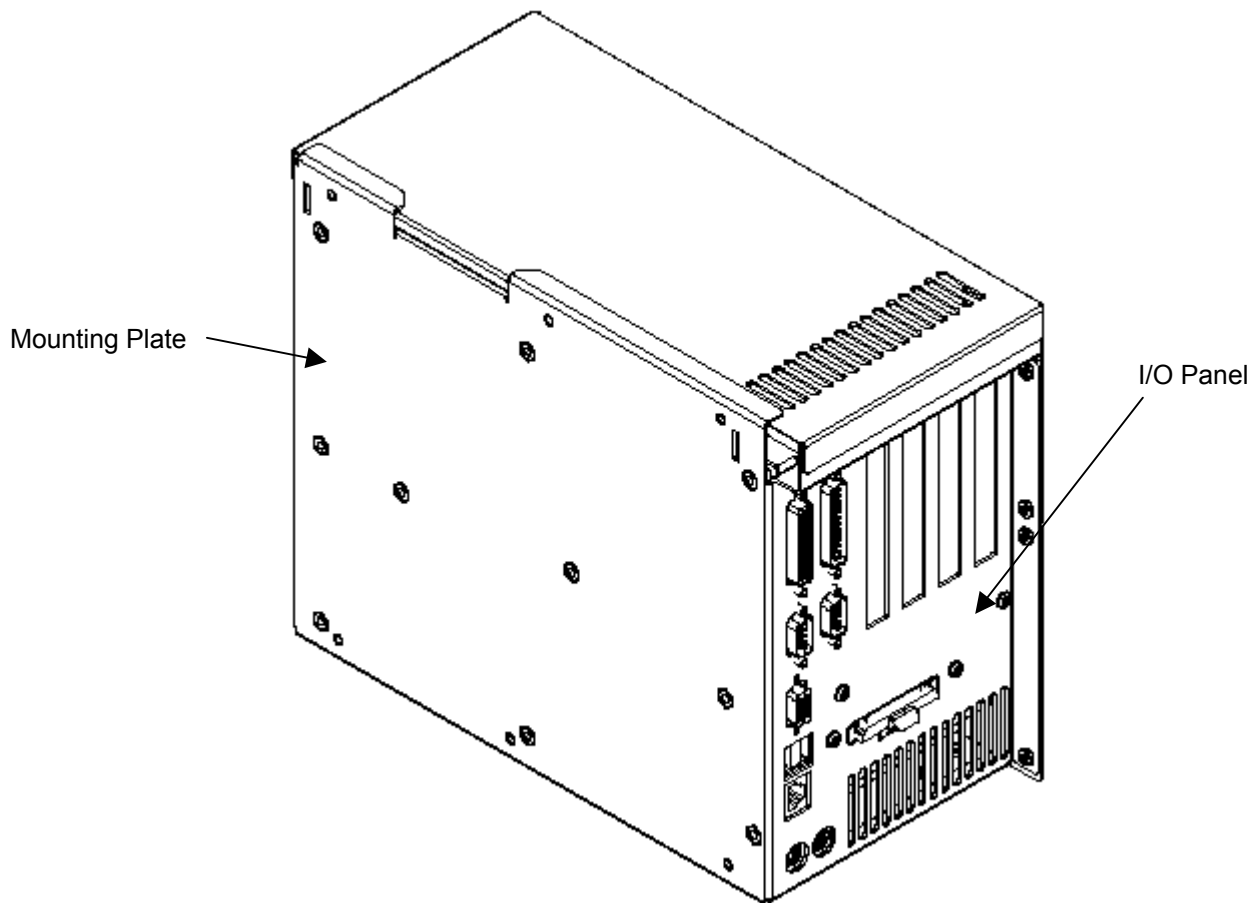

Figure 2–1. 1506 Mounting Plate

1507 Mounting Plate

The 1507 mounting plate protects the system’s interior when the system is properly mounted (refer to the *Mounting Considerations* and *Mounting Instructions* sections later in this chapter).

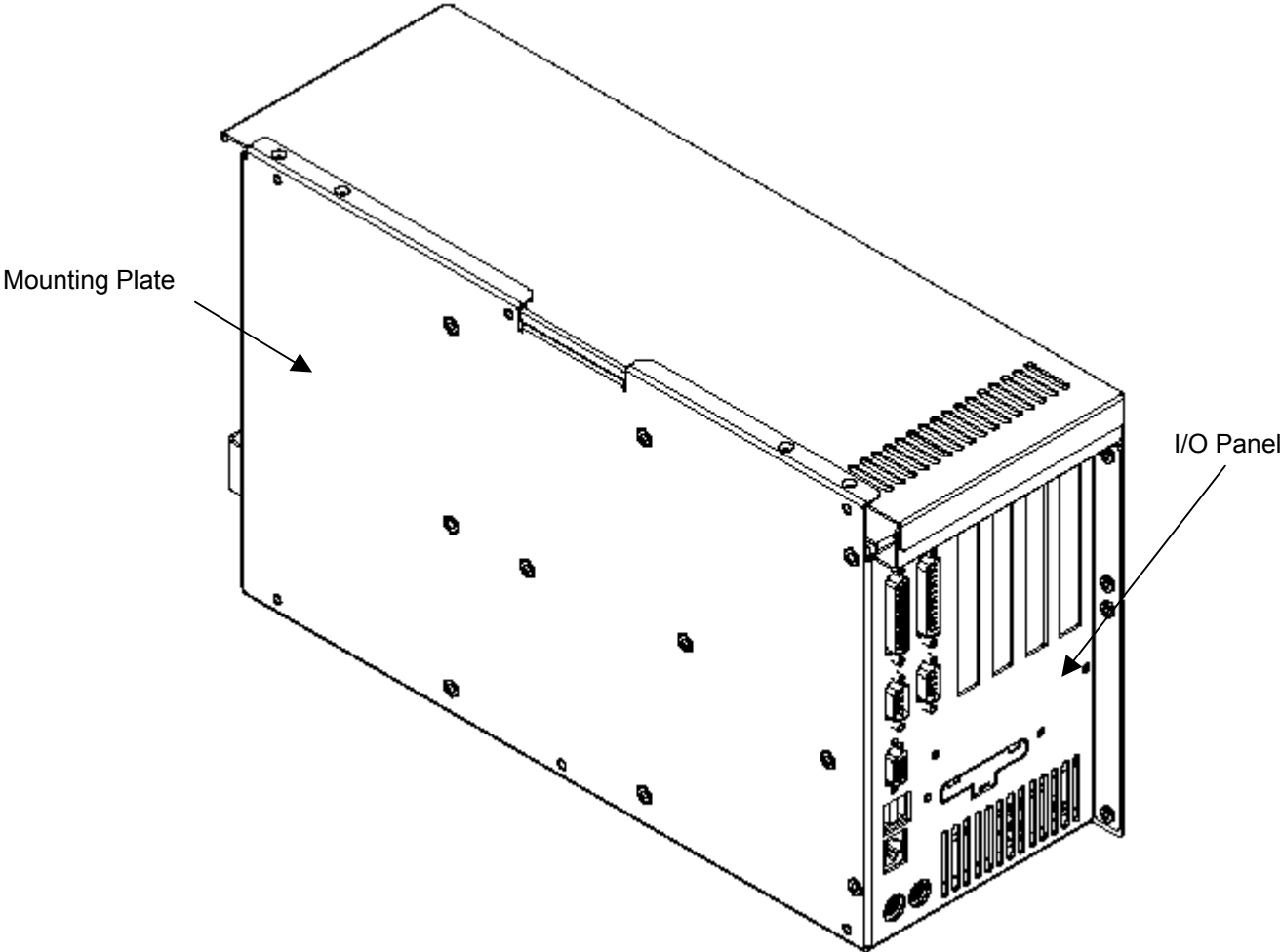

Figure 2–2. 1507 Mounting Plate

Back Panels and Power Panels

1506 Back Panel and Power Panel

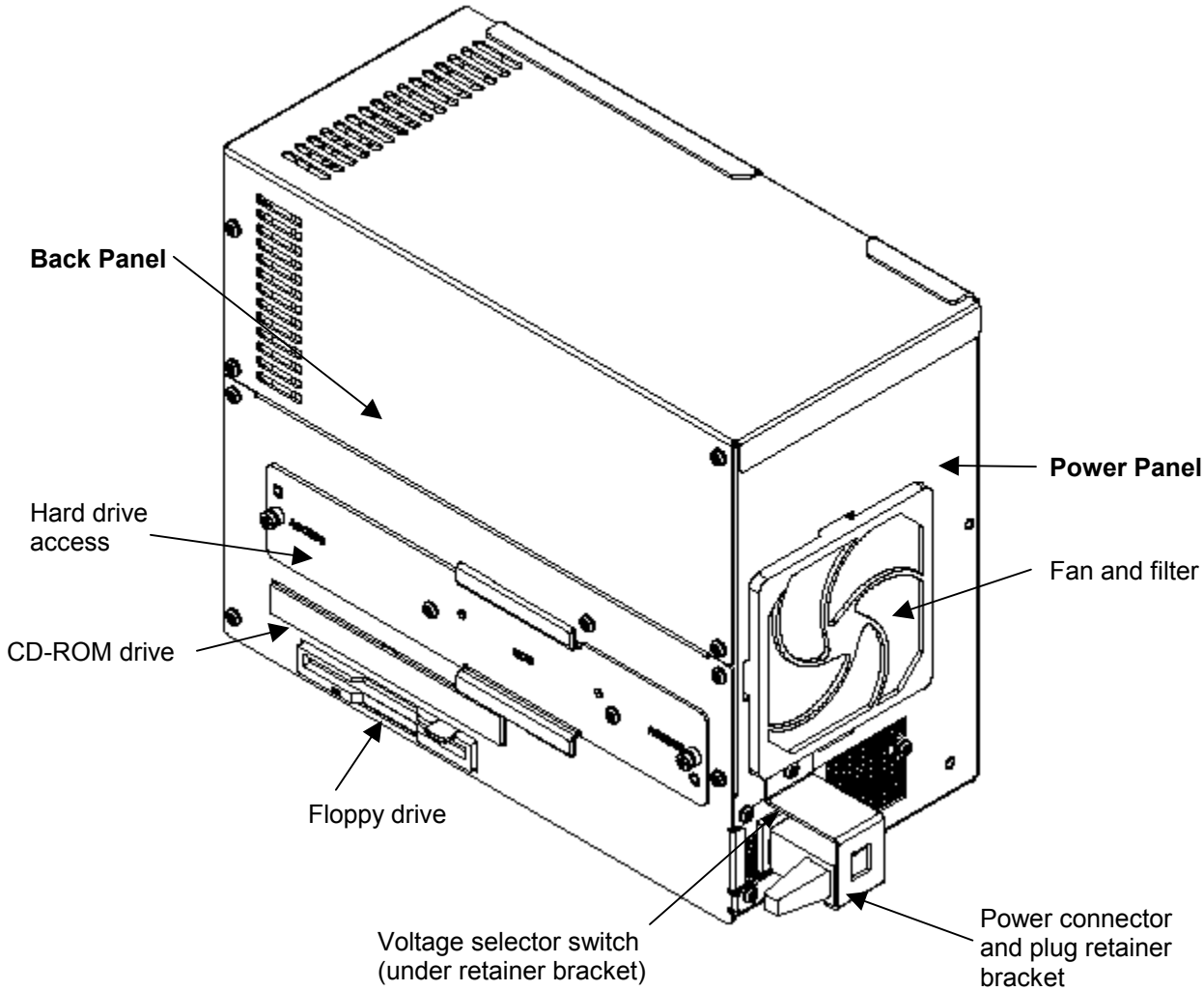

Figure 2-3. 1506 Back Panel and Power Panel

1507 Back Panel and Power Panel

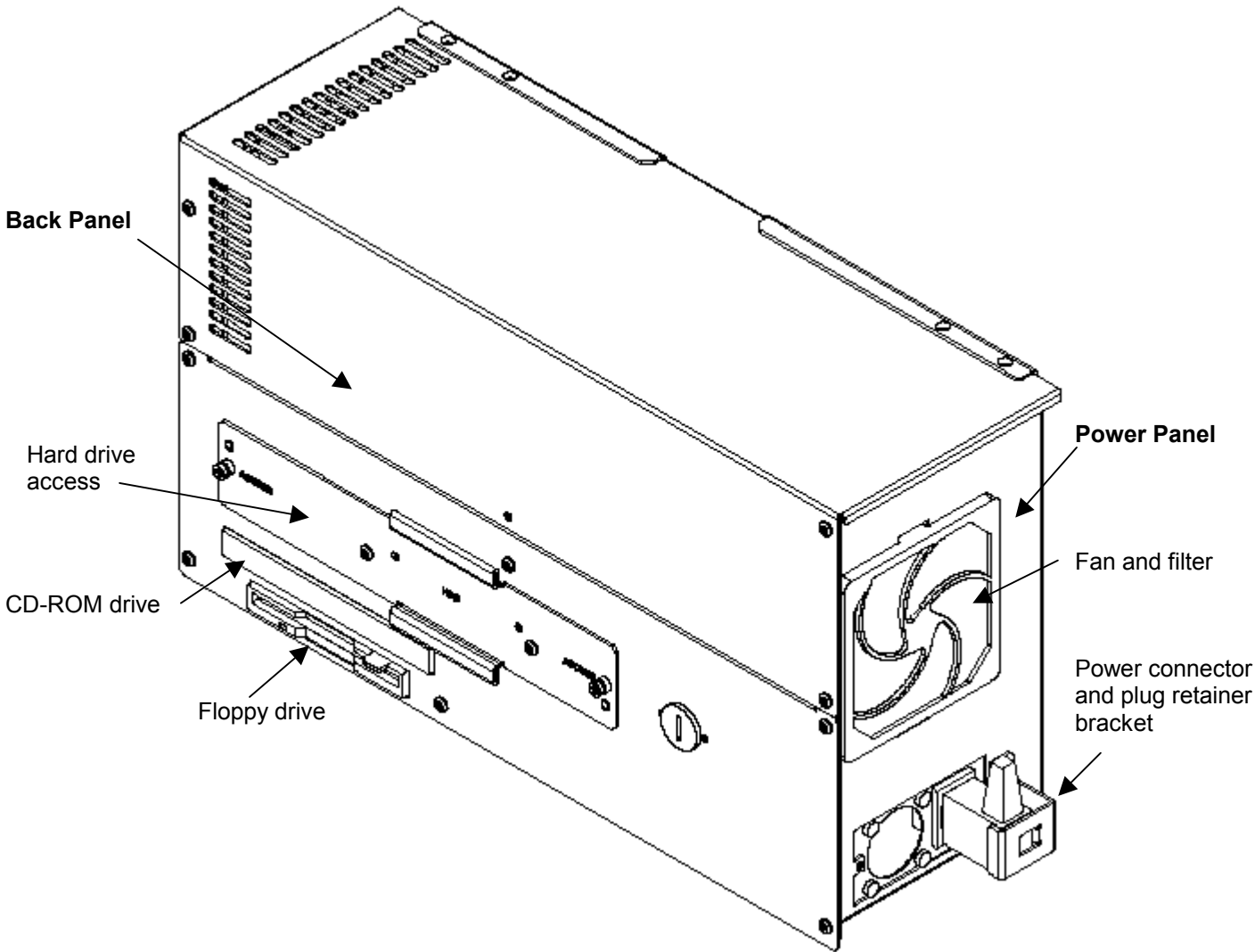

Figure 2-4. 1507 Back Panel and Power Panel

1506 and 1507 I/O Panel

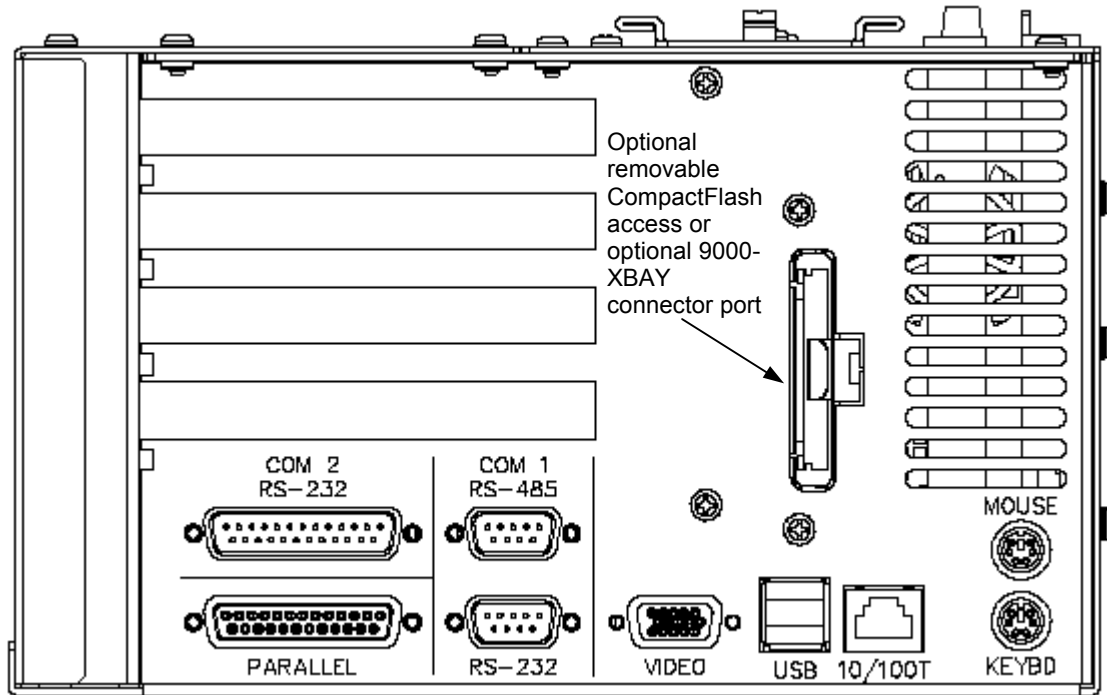

Figure 2-5. 1506 I/O Panel

Table 2–1. 1506 and 1507 I/O Panel

Feature	Description
Parallel Port	The parallel printer port (LPT1) is a DB-25 pin female connector. This port provides a standard PC-compatible printer interface.
COM Ports	COM1 is RS-232/485 compatible. RS/232 is connected to the lower 9-pin stacked DB connector. The top part of this stack is the RS/485 version of the same port. Since these connectors are attached to the same port, only one can be used at a time. COM2 is the male 25-pin DB connector. An external push-button reset option and alarm feature is available. Consult the AIM3 CPU manual for the jumper that controls this option.
Keyboard Port	The keyboard port is a PS/2 [®] stacked mini-DIN so a PC/AT [®] keyboard can be attached at the side of the unit. The keyboard port on the side of the unit is the lower connector. Warning: To maintain a safe condition, do not use an external keyboard and/or mouse port when the unit is operating in a hazardous environment.
Mouse Port	The mouse port is a PS/2 stacked mini-DIN that allows you to attach a mouse at the side of the unit. Warning: To maintain a safe condition, do not use an external keyboard and/or mouse port when the unit is operating in a hazardous environment.
Video Port	The video port is a 15-pin D-sub VGA connector at the side of the unit. This connector supports any standard VGA connection. Both the LCD flat panel and video port are active as a default at boot time if video display devices are connected to them.
USB	The duplex Universal Serial Bus (USB) port provides connectivity for USB 1.1 peripherals and hubs.
Ethernet Port	On-board 10/100 Base T RJ-45 Ethernet connector
Removable CompactFlash [™] access (optional)*	This option allows external access to Type I or Type II CompactFlash [™] for solid state storage media. Note: This feature cannot be used if the removable CompactFlash[™] option was not ordered.
9000-XBAY connector port (optional)*	The 9000-XBAY connector port is a factory-installed option that provides a connection from the 1506/1507 to any two IDE devices used by the optional 9000-XBAY. Note: This feature cannot be used if the 9000-XBAY option was not ordered.

* This port can be used for the removable CompactFlash[™] or the external bay connector but *not* both. If the user chooses one of these options, it must be factory installed.

Preparing the System

Warning

For hazardous locations installation, review the *Hazardous Locations Installation* section in this chapter before startup.

Read this chapter first, comply with all the safety requirements, and then mount the unit according to the following instructions.

1. Locate a position that meets the required specifications listed in the *Mounting Considerations* section of this chapter, and also in Appendix A.
2. Create a panel mounting location. Reference the *Mounting the Unit* section of this chapter for vertical and horizontal mounting dimensions.
3. Install optional equipment following the instructions in *Installing Internal Hardware Options* in this chapter.
4. Construct a power cable. Refer to *AC Power Cable* in this chapter.
5. Mount the unit and properly secure it into an enclosure. See *Installing the System* in this chapter.
6. On **1506** units, attach one end of the power cord to the power receptacle on the unit and the other end to a properly grounded 100-132/200-240 VAC, 50-60 Hz outlet.

On **1507** units, attach one end of the power cord to the power receptacle on the unit and the other end to a properly grounded 100-240 VAC, 50-60 Hz outlet.

Caution

Check that the voltage selector switch is set to the appropriate position.

7. Turn on power to the system. The system will boot up the installed operating system.
8. Install the application software via a floppy drive, CD-ROM, or the network.

Installing Internal Hardware Options

Remove the lid to install internal hardware options.

Caution

Turn off the unit before installing internal hardware.

Warning

Installation of expansion boards may void safety and/or EMC compliance.

DRAM and Additional DRAM Dual Inline Memory Modules (DIMMs)

You can order the 1506 and 1507 systems factory-configured for many configurations of DRAM. You can reconfigure the DRAM capacity by changing the DRAM DIMMs on your board. For more information refer to the AIM3 CPU manual.

PC/AT[®] and PCI Boards

1. Check the memory and I/O configuration of the board you want to install so that it does not conflict with the CPU and I/O memory maps in your AIM3 CPU board manual.
2. Remove the lid.
3. Remove the ORB screw from the desired slot.
4. Slide the PC/AT expansion board into the corresponding rail.
5. Push the board into the backplane connectors.

Caution

DO NOT force the boards or apply uneven pressure.

Caution

Make sure boards do not exceed the power limitations of the 1506 and/or 1507. Refer to tables 2–2 and 2–3.

6. Secure the board by installing the screw through the hole in the board's metal ORB and into the top of the track.
7. Replace the lid.

Installing the System Within an Enclosure

The rugged design of the 1506 and 1507 allows them to be installed in most industrial environments. The systems are generally placed in NEMA 4/4X/12 enclosures to protect against contaminants such as dust, moisture, etc. Metal enclosures also help minimize the effects of electromagnetic radiation that nearby equipment can generate. For Underwriters Laboratories compliance, the unit must be installed within a suitable fire enclosure.

Mounting Considerations

Once you have established a location for the 1506 or 1507, install it in the enclosure according to the instructions that follow:

- Select a NEMA rated enclosure and place the unit to allow easy access to the system ports.
- Account for the unit's depth when choosing the depth of the enclosure.
- Provide a NEMA 4 seal by mounting the unit in an approved enclosure.
- Consider locations of accessories such as AC power outlets and lighting (interior lighting and windows) for installation and maintenance convenience.
- Prevent condensation by installing a thermostat-controlled heater or air conditioner.
- To allow for maximum cooling avoid obstructing the airflow.
- Place any fans or blowers close to the heat generating devices. If using a fan, make sure that outside air is not brought inside the enclosure unless a fabric or other reliable filter is used. This filtration prevents conductive particles or other harmful contaminants from entering the enclosure.
- Do not select a location near equipment that generates excessive electromagnetic interference (EMI) or radio frequency interface (RFI) (equipment such as high power welding machines, induction heating equipment, and large motor starters).
- Place incoming power line devices (such as isolation or constant voltage transformers, local power disconnects, and surge suppressers) away from the system. The proper location of incoming line devices keeps power wire runs as short as possible and minimizes electrical noise transmitted to the unit.
- Make sure the location does not exceed the unit's shock, vibration, and temperature specifications.
- Install in such a way as to ensure that it does not cause a hazard from uneven mechanical loading.
- Incorporate a readily accessible disconnect device in the fixed wiring on permanently connected equipment. The disconnect device must be located in a non-hazardous location.
- Avoid circuit overloading of the supply circuit.

A pair of mounting rails is provided with the unit. These rails can be attached to the unit so that it can be mounted in either of the two orientations shown on the

following pages. The rails are to be attached to the unit using the 6 provided 6-32 UNC-2A x 1/4" screws tightened to 21 lbs-inch.

The unit can then be mounted to a panel, bench, shelf, etc, using the 4 provided 10-32 UNF-2A x 5/8" screws tightened to 25 lbs-inch.

System Power

Using isolation transformers on the incoming AC power line to the system is always a good practice. An isolation transformer is especially desirable in cases in which heavy equipment is likely to introduce noise onto the AC line.

The isolation transformer can also serve as a step-down transformer to reduce the incoming line voltage to a desired level. The transformer should have a sufficient power rating (units of volt-amperes) to supply the load adequately.

Proper grounding is essential to all safe electrical installations. Refer to the relevant Federal, State/Provincial, and local electric codes, which provide data such as the size and types of conductors, color codes and connections necessary for safe grounding of electrical components. The code specifies that a grounding path must be permanent (no solder), continuous, and able to safely conduct the ground-fault current in the system with minimal impedance (minimum wire required is #18 AWG, 1 mm).

Observe the following practices:

- Separate ground wires (P.E. or Protective Earth) from power wires at the point of entry to the enclosure. To minimize the ground wire length within the enclosure, locate the ground reference point near the point of entry for the plant power supply.
- All electrical racks or chassis and machine elements should be Earth Grounded in installations where high levels of electrical noise can be expected. The rack/chassis should be grounded with a ground rod or attached to nearby Earth structure such as a steel support beam. Each different apparatus should be connected to a single Earth Ground point in a "star" configuration with low impedance cable. Scrape away paint and other nonconductive material from the area where a chassis makes contact with the enclosure.
- In addition to the ground connection made through the mounting bolt or stud, use a one-inch metal braid or size #8 AWG wire to connect between each chassis and the enclosure at the mounting bolt or stud.

Excessive Heat

The units withstand temperatures from 0° to 50°C, and are fan-cooled. To keep the temperature in range, the cooling air at the base of the system must not exceed 50°C. Allocate proper spacing between internal components installed in the enclosure. Units with standard BIOS release 1.3 or greater will automatically throttle down the CPU speed if the temperature exceeds the maximum allowed CPU temperature.

Electrical Noise

Electrical noise is seldom responsible for damaging components, unless extremely high energy or high voltage levels are present. However, noise can cause temporary malfunctions, which can result in hazardous machine operation in certain applications. Noise may be present only at certain times, may appear at widespread intervals, or in some cases may exist continuously.

Noise commonly enters through input, output, and power supply lines and may also be coupled through the capacitance between these lines and noise signal carrier lines. This usually results from the presence of high voltage or long, close-spaced conductors. When control lines are closely spaced with lines carrying large currents, the coupling of magnetic fields can also occur. Use shielded cables to help minimize noise. Potential noise generators include switching components, relays, solenoids, motors, and motor starters.

Refer to the relevant Federal, State/Provincial, and local electric codes, which provide data such as the size and types of conductors, color codes and connections necessary for safe grounding of electrical components. It is recommended that the high voltage and low voltage cabling be separated and dressed apart. In particular, the AC cables and switch wiring should not be in the same conduit with all communication cables.

Line Voltage Variation

The unit's power supply is built to operate with input voltage ranges of 100-132/200-240 VAC (1506), or 100-240 VAC (1507) while still allowing the system to function within its operating margin. As long as the incoming voltage is adequate, the power supply provides all the logic voltages necessary to support the processor, memory, and I/O.

In cases in which the installation is subject to unusual AC line variations, use a constant voltage transformer to prevent the system from shutting down too often. However, a first step toward the solution of the line variations is to correct any possible feed problem in the distribution system. If this correction does not solve the problem, use a constant voltage transformer.

The constant voltage transformer stabilizes the input voltage to the 1506 and 1507 units by compensating for voltage changes at the primary in order to maintain a steady voltage at the secondary. When using a constant voltage transformer, check that the power rating is sufficient to supply the unit.

AC Power Cable

A power cable must be created to supply power to the unit. The following materials are needed:

- A three-position power connector (supplied)
- A braid/foil shielded power cable, terminated at power source end, with three #18 (1.0 mm), #16 (1.3 mm), or #14 (1.6 mm) AWG solid or stranded copper wires, rated 80°C or better

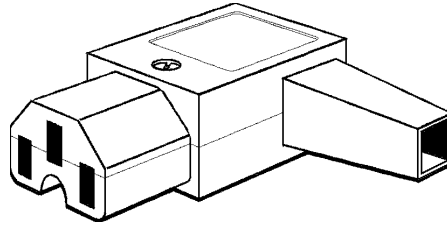

Figure 2-6. 1506/1507 AC Power Connector.

Perform the following steps to construct and attach the cable:

1. Cut wire cable to the desired length.
2. Strip 0.25-inch (6 mm) of insulation from the end of the conductor wire. No bare wire should be exposed when the cable is connected to the workstation.
3. Tin the wire ends with solder if using stranded wire. This will keep the wire from fraying.

Warning

When inserting the wire ends of the power cable into the block plug, be sure there is no exposed wire. Trim the wire ends of the cable or cut a new cable if necessary.

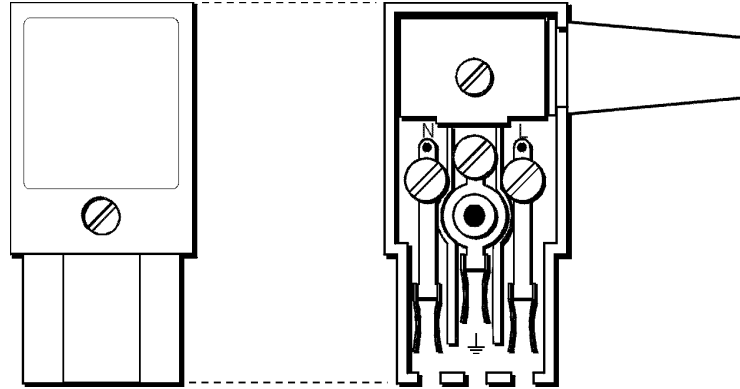

Figure 2-7. Internal View of 1506/1507 AC Power Connector

4. Insert the three wire ends of the power cable into the hole of the connector plug. Bend the Protective Earth ground (PE) wire, the neutral (N) wire, and the line (L) wire around the corresponding screw. Be sure that no bare wires are exposed.
5. Tighten the three screws above the wires to hold them firmly in place.

Warning

Never tighten the three screws of the block plug when the cable is connected to a power source. The screws are conductive and have full contact with the cable wire.

6. Use the screw provided to secure and strain-relief the power cable inside the connector. Plug the power cable into the power supply located on the side of the unit. Install the plug retainer bracket over the plug (mandatory for hazardous location installations).
7. Once the power cable and other optional interface cables are installed, installation is complete.

Note

When disconnecting the power cord from the unit, be sure to completely loosen the two securing screws on the retainer bracket.

1506 Power Supply

The 1506 node box has a 90-watt AC power supply with 38 watts maximum of available expansion power. The expansion power is limited as shown in table 2–2.

Table 2–2. 1506 Available Expansion Current

Voltage	Available Current
+3.3 VDC	4.0A
+5.0 VDC	5.7A
-5.0 VDC	160mA
+12.0 VDC	0.58A
-12.0 VDC	160mA
Caution: +5V and +3.3V combined shall not exceed 28 watts. -5V and -12V combined shall not exceed 2 watts.	

1507 Power Supply

The 1507 node box has a 200-watt AC power supply with 66 watts maximum of available expansion power. The expansion power is limited as shown in table 2–3.

Table 2–3. 1507 Available Expansion Current

Voltage	Available Current
+3.3 VDC	10.0A
+5.0 VDC	12.0A
-5.0 VDC	0.2A
+12.0 VDC	4.9A
-12.0 VDC	0.5A
Caution: 3.3V and 5.0V combined shall not exceed 66 watts.	

Mounting the Unit

Once the mounting considerations listed earlier in this chapter have been met, mount the 1506 or 1507 according to the following instructions.

1. Locate a position for your 1506 or 1507 that meets the specifications required (see previous sections and Appendix A).
2. Create a panel mounting location. Reference the *Mounting the Unit* section of this chapter for vertical and horizontal mounting dimensions.
3. Mount and secure the unit. Refer to *Installing the System* in this chapter.
4. On **1506** units, attach one end of the power cord to the power receptacle on the unit and the other end to a properly grounded 100-132/200-240 VAC, 50-60 Hz outlet.

On **1507** units, attach one end of the power cord to the power receptacle on the unit and the other end to a properly grounded 100-240 VAC, 50-60 Hz outlet.

Caution

Check that the voltage selector switch is set to the appropriate position.

5. Attach the connector retainer bracket (mandatory for hazardous locations).
6. Turn on the power. The system will boot up to the operating system installed.
7. Install application software via a floppy drive or CD-ROM.

Note

If panel or wall mounting is chosen, attach mounting rails with six 6-32 x ¼" screws (provided) and torque to 21 pound-inches.

System Mounting Dimensions

1506 Vertical Mounting

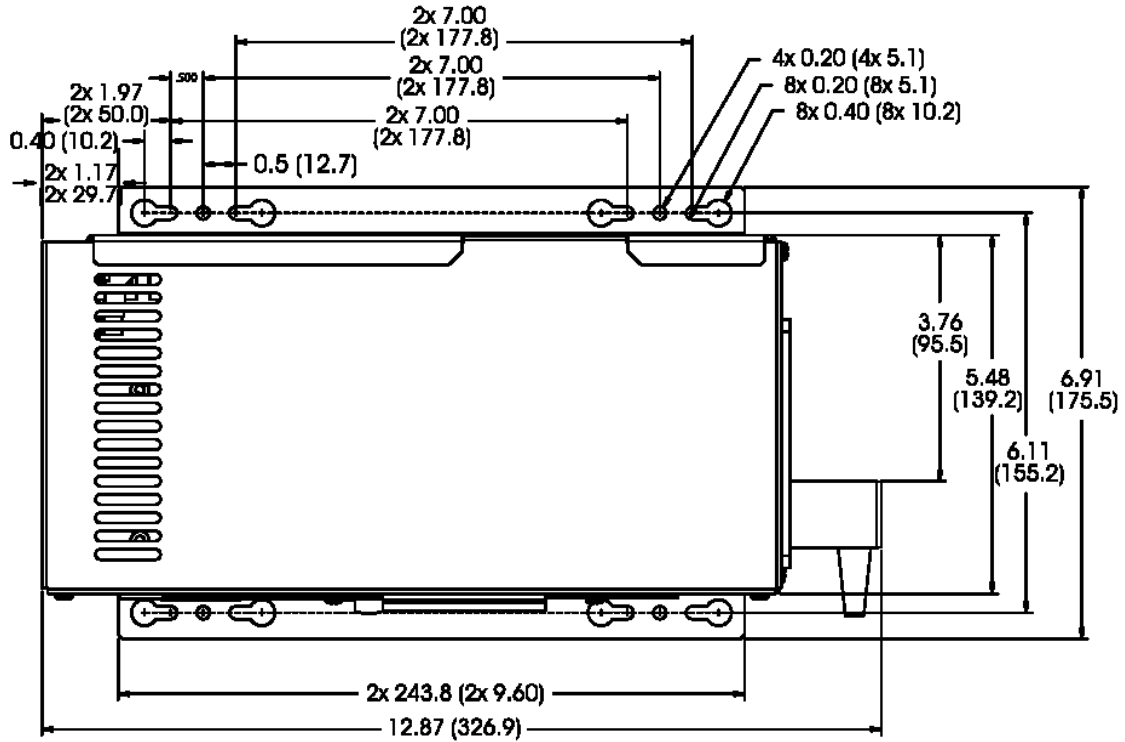

All dimensions in inches (mm)

Figure 2–8. 1506 Vertical Mounting Dimensions (with mounting rails attached)

1506 Horizontal Mounting

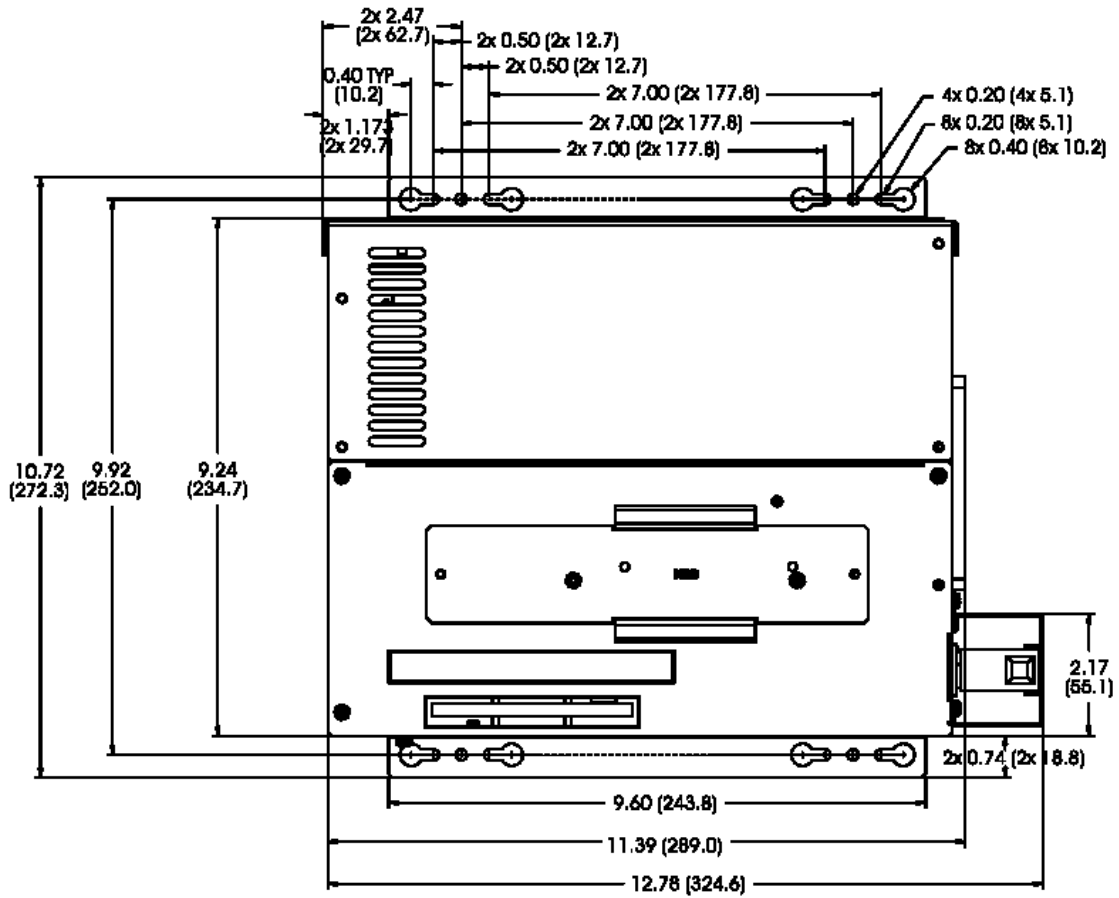

All dimensions in inches (mm)

Figure 2-9. 1506 Horizontal Mounting Dimensions

1507 Vertical Mounting

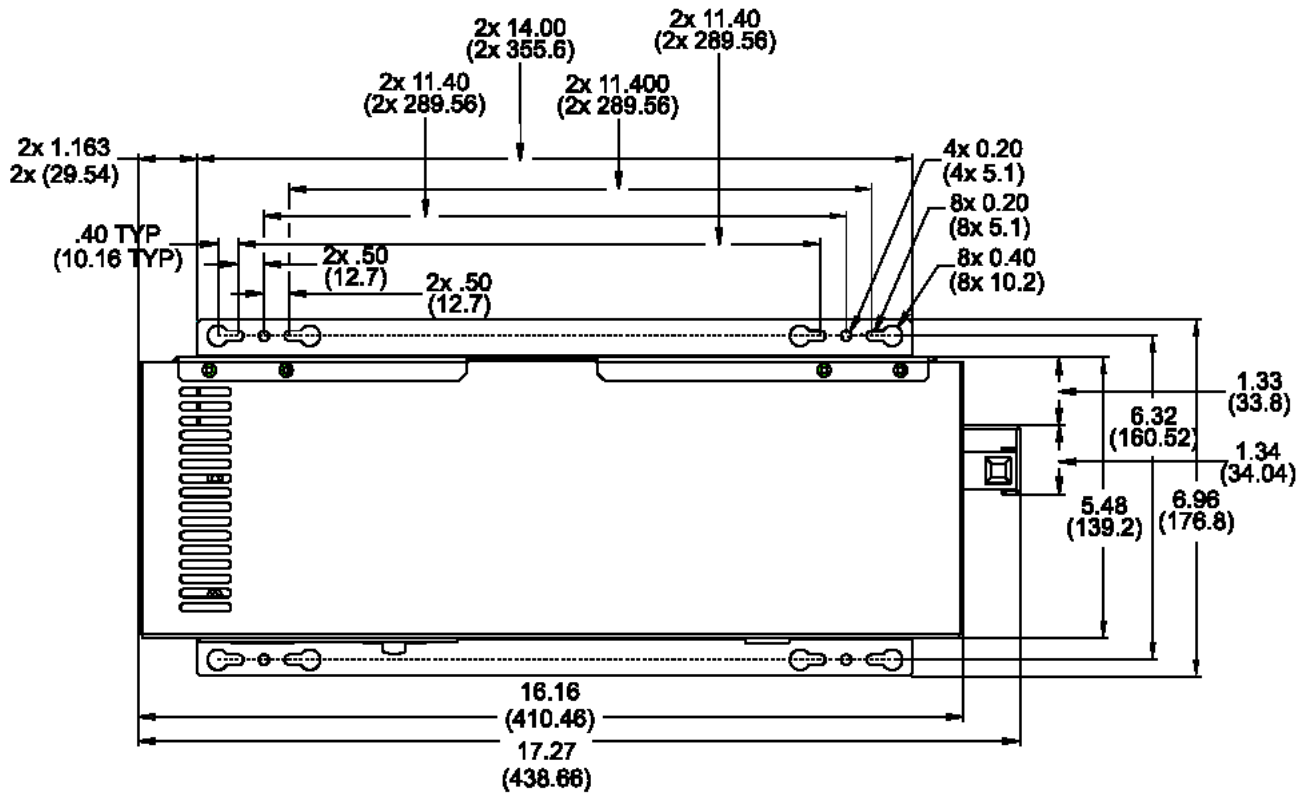

All dimensions in inches (mm)

Figure 2-10. 1507 Vertical Mounting Dimensions

1507 Horizontal Mounting

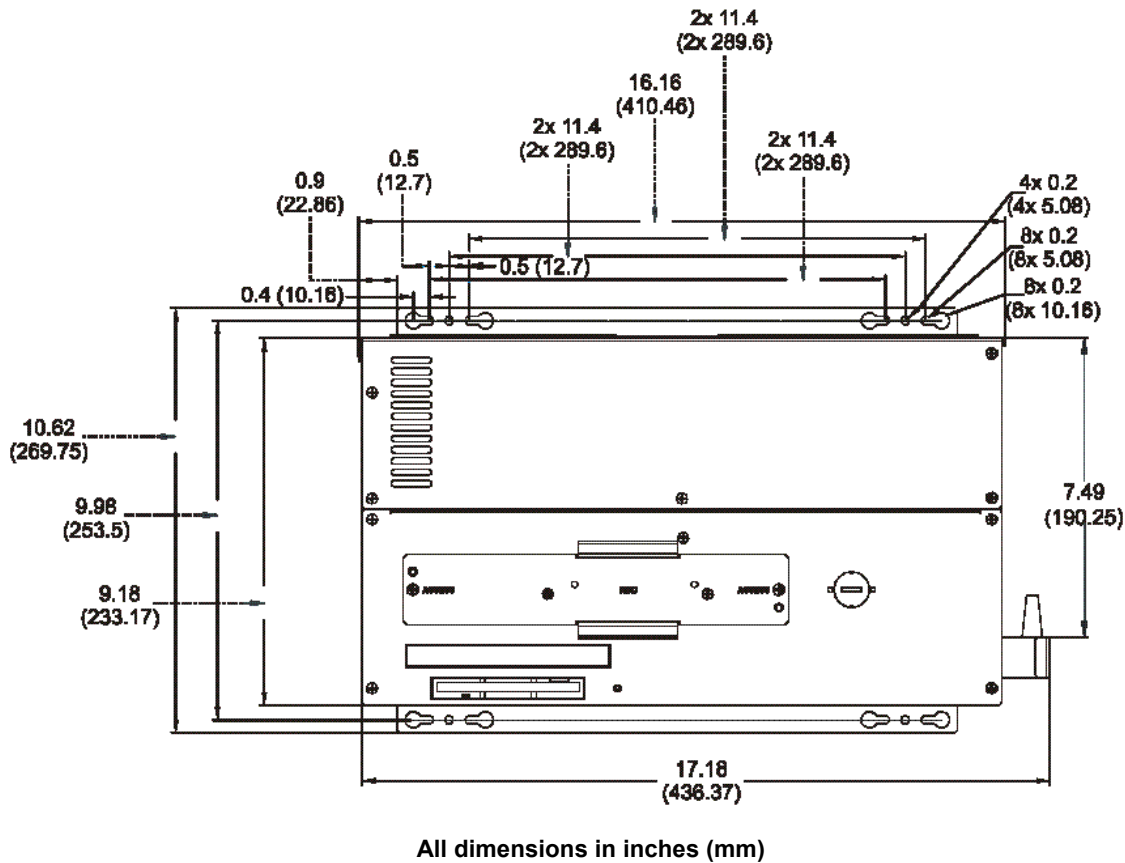

Figure 2–11. 1507 Horizontal Mounting Dimensions

Hazardous Locations Installation

Xycom Automation designed the 1506 and 1507 Node Box Industrial PCs to meet the requirements of Class I, Division 2 Hazardous Locations applications. Division 2 locations are those locations that are normally non-hazardous, but could become hazardous due to accidents that may expose the area to flammable vapors, gases or combustible dusts.

These systems have been designed as non-incendiary devices. They are not intrinsically safe and should never be operated within a Division 1 (normally hazardous) location when installed as described here. Nor should any peripheral interface device attached to these systems be located within Division 1 locations unless approved and/or certified diode barriers are placed in series with each individual signal and DC power line. Any such installations are beyond the bounds of Xycom design intent. **Xycom Automation accepts no responsibility for installations of this equipment or any devices attached to this equipment in Division 1 locations.**

Note

It is the customer's responsibility, when adding additional cards, that they meet operating conditions for Class I, Division 2 hazardous locations. Additions and/or modifications without express consent from UL and/or Xycom Automation will void Hazardous Locations compliance.

It is the responsibility of the customer to ensure that the product is properly rated for the location. If the intended location does not presently have a Class, Division, and Group rating, then users should consult the appropriate authorities having jurisdiction in order to determine the correct rating for that Hazardous Location.

In accordance with Federal, State/Provincial, and Local regulations, all hazardous locations installations should be inspected by the appropriate authority having jurisdiction prior to use. Only technically qualified personnel should install, service, and inspect these systems.

Warning

In order to maintain a safe condition, do not use an external keyboard or mouse when the unit is operating in a hazardous environment.

Safety Agency Approval

The Xycom Automation systems have the following approvals:

- *Underwriters Laboratories Inc., UL 1604 Standard for Safety.* Electrical equipment for use in Class I and Class II, Division 2, and Class III hazardous (classified) locations. (UL Listed, File E180970)
- *Underwriters Laboratories Inc., UL 60950, "Safety of Information Technology Equipment."* (UL Recognized, File E181675)
- *Canadian Standard Association, Specification C22.2 No. 213-M1987.* Non-incendiary electrical equipment for use in Class I, Division 2 hazardous locations. (cUL Listed, File E180970)
- *Canadian Standards Association, Specification C22.2 No. 950, "Safety of Information Technology Equipment."* (cUL Recognized, File E181675).

Warning

Suitable for use in Class I, Division 2 Groups A, B, C, and D hazardous locations or non-hazardous locations only.

Warning – Explosion Hazard

Substitution of components may impair suitability for Class I, Division 2.

Avertissement – Risque d’Explosion

La substitution de composants peut rendre ce materiel inacceptable pour les emplacements de classe I, Division 2.

Warning – Explosion Hazard

Do not disconnect equipment unless the power has been switched off or the area is known to be non-hazardous.

Avertissement – Risque d’Explosion

Avant de deconnecter l’equiment, coupler le courant ou s’assurer que l’emplacement est designe non dangereux.

Warning – Explosion Hazard

When in hazardous locations, turn off power before replacing or wiring modules.

Avertissement – Risque d’Explosion

Dans les situations hasardees, couper la courant avant de remplacer ou de cabler les modules.

Definitions

The following Class and Division explanations are derived from Article 500 (Sections 5 and 6) of the United States National Fire Protection Agency National Electric Code (NFPA 70, 1990). They are not complete and are included here only for a general description for those not familiar with generic hazardous locations' requirements.

Persons responsible for the installation of this equipment in Hazardous Locations are responsible for ensuring that all relevant codes and regulations related to location rating, enclosure, and wiring are met.

Class I Locations

Class I locations are those in which flammable gases or vapors are or may be present in the air in quantities sufficient to produce explosive or ignitable mixtures.

Class II Locations

Class II locations are those that are, or may become, hazardous because of the presence of combustible dust.

Division 1 Locations

A Division 1 location is one in which flammable or ignitable gasses, vapors, or combustible dusts and particles can exist due the following conditions:

- Normal operating conditions;
- Because of repair, maintenance conditions, leakage, or mechanical failure or abnormal operation of machinery or equipment; or
- Combustible dusts of an electrically conductive nature may be present in hazardous quantities.

Note

Xycom Automation systems are not suitable for installation within Division 1 locations.

Note

Electrical equipment cannot be installed in Division 1 locations unless they are intrinsically safe, installed inside approved explosion-proof enclosures, or installed inside approved purged and pressurized enclosures.

Division 2 Locations

Division 2 locations are listed below:

- Class I volatile flammable liquids or flammable gasses are handled, processed, or used, but confined within closed containers or closed systems from which they can escape only in cases of accidental rupture or breakdown of such enclosures or systems, or in case of abnormal operation of equipment.
- Ignitable concentrations of Class I vapors or gasses are normally prevented by positive mechanical ventilation, but which may become hazardous due to mechanical failure of those ventilation systems.
- Location is adjacent to a Division 1 location.
- Class II combustible dust is not normally in the air in quantities sufficient to produce explosive or ignitable mixtures. Dust accumulations are normally insufficient to interfere with normal operation of electrical equipment or other apparatus. Combustible dust may be in suspension in the air as a result of the following: malfunctioning of handling or processing equipment; combustible dust accumulations on, or in the vicinity of electrical equipment; may be ignitable by abnormal operation or failure of electrical equipment.

Groups

All electrical equipment that is approved for use in hazardous locations must include a group rating. Various flammable and combustible substances are divided into these groups as a function of their individual maximum experimental safe gap (MESG), explosion pressure, and ignition temperature.

Component temperatures and the potential for spark based upon voltage, current, and circuit characteristics, within electrical equipment, will determine what the equipment group rating will be. A device approved for installation within Class I, Group A locations may also be used in Groups B, C, or D.

Note

Approved Class I equipment may not be suitable for Class II installations. Class I includes Groups A, B, C, and D. Class II includes Groups F, and G.

Enclosures

The systems are designed for installation within a clean and dry enclosure for both ordinary and hazardous locations. The enclosure used for Class I hazardous locations should have a minimum rating of Type 12 (NEMA 12, IP 5X). However, Type 4 (IP 6X) enclosures are strongly recommended.

The requirements for enclosure fittings, conduit, and wiring vary according to the specific rating of the location and the type of flammable or combustible material involved. Those requirements are beyond the scope of this document and it is the responsibility of the customer to ensure that their installation is compliant with codes and regulations that apply to their specific location. Reference NFPA 70, Article 500 for specific regulations in the United States.

Power Switch

The 1506 and 1507 systems do not have a power switch. The amount of input power required by these systems classifies the power switch as an incendiary device because the voltage and current across the make/break device are capable of creating a spark.

Hazardous locations' regulations require that a power switch rated for ordinary locations may be used if it is located in an area specified as non-hazardous. However, limits in cable length between the workstation and the power switch may apply. Otherwise the switch must be compliant with Class I, Division 1 requirements (intrinsically safe). These switches are built in a manner that prevents the possibility of a spark when contacts are made or broken.

Use suitable UL listed and/or CSA Certified Class I, Division 1 switches in hazardous locations. These switches are available from a wide number of sources. It is the responsibility of the customer to ensure that the power switch selected for their installation has the correct hazardous locations rating for the location in which it is installed.

Cable Connections

Division 2 hazardous location regulations require that all cable connections be provided with adequate strain relief and positive interlock. Never connect or disconnect a cable while power is applied at either end of the cable.

Communication Cable Interface

All communication cables should include a chassis ground shield. This shield should include both copper braid and aluminum foil. The D-sub style connector housing should be a metal conductive type (e.g., molded zinc) and the ground shield braid should be well terminated directly to the connector housing. Do not use a shield drain wire.

The outer diameter of the cable must be suited to the inner diameter of the cable connector strain relief in order to ensure that a reliable degree of strain relief is maintained. Always secure the D-Sub connectors to the workstation mating connectors via the two screws located on both sides.

Warning

Never connect or disconnect the communication cables while power is applied at either end of the cable. This may result in an incendiary spark. Permanent damage to the workstation communication components may occur.

Operation and Maintenance

The systems have been designed for compliance with relevant spark ignition tests. However, please note that the workstation front panel contrast adjustment tactile switches and keyboard connector are the only make/break components intended to be exercised by the operator in the course of normal operation.

Warning

In order to maintain a safe condition, never use an external keyboard or mouse when the unit is operating in the presence of a hazardous environment.

With respect to Hazardous Location installations, always observe the following rules:

1. Always install the 1506 or 1507 within an enclosure suitable for the specific application. Type 4 (IP 65) enclosures are recommended even when not required by regulations.
2. If present, keep enclosure doors or openings closed at all times, to avoid the accumulation of foreign matter inside the workstation.
3. Never subject the unit to any installation or service procedures unless power has been removed and the area is known to be non-hazardous. This includes the

installation or removal of power cables, communication cables, or removal of the rear cover of the unit.

4. Only technically qualified service personnel should perform all installation and service. These workstations are designed to require no service in the course of normal operation by an operator.

Chapter 3 – Maintenance

The 1506 and 1507 systems are designed to withstand the harsh environment of the factory floor. Routine maintenance can help keep your system in good operating condition. Preventive maintenance consists of several basic procedures that will greatly reduce the chance of system malfunction. Schedule preventive maintenance along with the regular equipment maintenance to minimize down time.

General Preventive Maintenance

Here are some preventive measures you can take:

- *Clean or change the fan filter periodically* to ensure that the air circulating in the unit is clean. Wash the filter with warm water and dish soap, and let it air dry. Do not scrub the filter, and do not reinstall it into the unit until it is completely dry.
- *Base your maintenance schedule* on the type of environment the system is in (i.e., if the area is dusty, you should schedule maintenance more often than if it is a dry, clean area). Check the filter often to determine if it needs to be changed ahead of schedule.
- *Remove dust and dirt from PC components.* If dust builds up on heat sinks and circuitry, an obstruction of heat dissipation could cause the unit to malfunction. If dust reaches the electronic boards, a short circuit could occur.
- *Check the connections to I/O modules,* especially in environments where vibration could loosen the connections. Check to see that all plugs, sockets, terminal strips, and module connections are solid.
- *Remove unnecessary articles, such as drawings or manuals, from the unit.* They can obstruct airflow and create hot spots, which cause the system to malfunction.
- *Do not place noise-generating equipment near the 1506 or 1507 unit.*

Fuse Replacement

The 1506 and 1507 units have no accessible fuse. Return the unit to the factory for fuse replacement.

Fan Filter Replacement

To change the fan filter, remove the grill and filter as illustrated in Figure 3–1 or replace the filter and snap the assembly back into position.

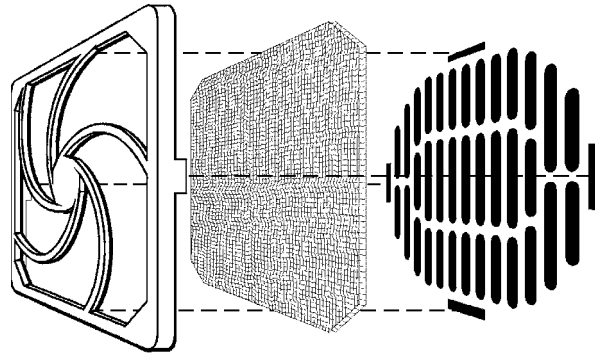

Figure 3–1. Fan Assembly

Caution

Do not operate the 1506 or 1507 without a fan filter. Dust build-up could cause the unit to malfunction.

Recommended Hard Drive Preventive Maintenance

Xycom Automation has recognized that hard drive failures may begin to increase an average of four to five years into the life of most computers used in industrial applications. Therefore, it is our recommendation as a preventive maintenance measure that all hard drives used in these types of applications be replaced before the four to five year time period to avoid any down time related to hard drive failure.

The purpose of this message is to merely bring this to our customer's attention, to offer alternative solutions, and to provide all of our customers with the excellent service they deserve.

Any questions regarding this issue may be directed to our support center at support@xycom.com.

Please note: Xycom recommends frequent backups of your hard drive, especially before beginning preventive maintenance procedures.

Product Repair Program / Returning a Unit to Xycom Automation

Xycom Automation's Product Repair & Customization Department (PR&C) restores equipment to normal operating condition and implements engineering changes that enhance operating specifications. Xycom Automation tests products returned to Xycom with the standard Xycom test diagnostics.

Follow the steps below to prepare the unit for shipment:

1. Obtain an RMA number for your unit by calling your nearest Xycom Automation Repair Department or Xycom Automation, Inc. at 734-429-4971 or 1-800-AT-XYCOM.
2. Please have the following information:
 - Company name, shipping and billing address
 - Type of service desired: product repair or product exchange
 - Product model number, part number, quantity, serial number(s), and warranty status
 - Failure mode and failure systems
 - Purchase order number or repair order number
3. Make sure the front panel assembly is properly attached to the unit.
4. Attach failure information to the unit to speed processing.
5. Place the unit securely in its original packaging or an equivalent heavy-duty box.
6. Mark the RMA number on your purchase order and on the outside of the box.
7. Send the unit to the address given when you receive your RMA number.

Chapter 4 – Troubleshooting

Diagnostic Testing

If you suspect that you are having hardware problems with your 1506 or 1507 system, you can use the Xycom diagnostic utility to check out the PC's various ports and subsystems. The diagnostic utility is on the Documentation and Support Library CD that was included with the your unit.

The first step is to create a diagnostic diskette. The following steps can be done on any computer with a CD-ROM drive:

1. Create a DOS-bootable diskette
2. Create a temporary folder on the computer hard drive
3. There is a self-extracting zip file on the Documentation and Support Library CD located in:

DRIVERS\Computer Diagnostics 99290-001\DOS\xydiag

Run that program and extract the files to the temporary folder you just created.

4. Copy the extracted files onto the DOS-bootable diskette.

When you have created the diskette, insert it into the 3600 unit's floppy drive and re-boot the unit. The menu in Figure 4–2, *Main Menu*, will appear following boot-up. Additional information on the tests is included in the .txt files on the diskette.

Perform the following steps **before** starting the system tests:

1. Place the CPU board jumpers and switches to the factory set positions. Refer to the AIM3 CPU manual for these settings.
2. Plug the female end of the AC power cable into the side of the unit and the male end into a properly grounded outlet.
3. Connect the serial loopback connector(s) and the printer cable to the appropriate connectors, and connect a PC/AT or PS/2 keyboard. Figure 4–1, *Serial Loopback Connections*, illustrates the wiring necessary for the loopback connection.
4. Default the CMOS setup to the factory settings.

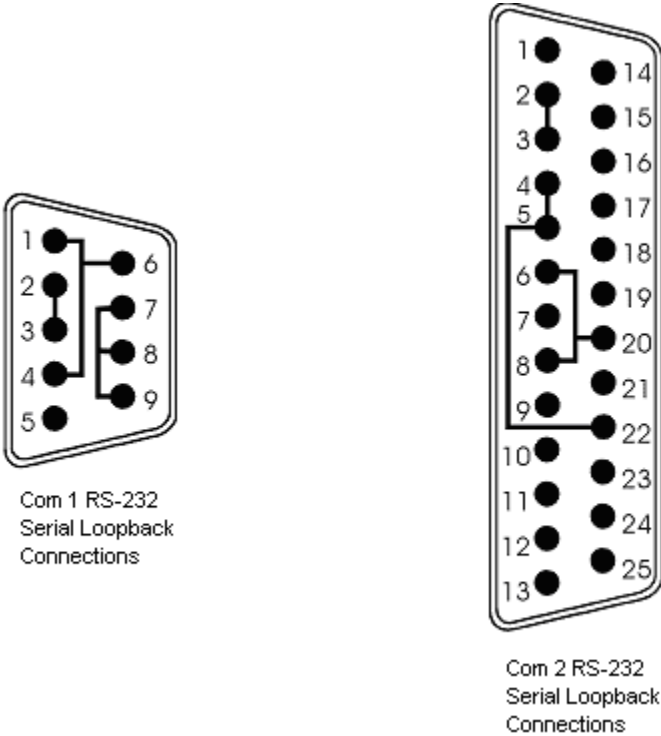

Figure 4-1. Serial Loopback Connections

Running the Tests

To run the test, insert the diagnostics disk into drive A. Turn on the computer (the diagnostics program will boot-up). Figure 4–2 shows the Main Menu.

```

          Copyright 2002, Xycom, Inc. All rights reserved.
          Diagnostic Tests Sequence/Selection Menu (Rel. xx)
1.  WILL pause on error           5.  Auto-select tests
2.  SINGLE PASS test mode        6.  Deselect all tests
3.  Save setup to file           7.  Quit and exit to DOS
4.  Extract setup from a file    8.  Return to previous screen
-----
A)  RAM Test
B)  Video RAM Test
C)  Extended RAM Test
D)  Real Time Clock Test
E)  COM1 Serial Port Test
F)  COM2 Serial Port Test
G)  COM3 Serial Port Test
H)  COM4 Serial Port Test
I)  Math Coprocessor Test
J)  Video Adjustments Test
K)  Video Interface Test
L)  Speaker Port Test
M)  LPT1: Printer Port Test
N)  LPT2: Printer Port Test
O)  C: Hard Drive Interface Test
P)  D: Hard Drive Interface Test
Q)  A: Floppy Drive Interface Test
R)  B: Floppy Drive Interface Test
S)  Keyboard, Keypad Tests
    = = Test Selected
-----
          [ENTER]=START TESTING
Use the letters to move the cursor and select/deselect, or use the arrow
keys to move, then use the [SPACE] key to select/deselect a test or
function.

```

Figure 4–2. Main Menu

Note

Please read the DIAG.TXT file on the diagnostics disk for detailed information about the tests.

Note

Avoid repeated running of any hard disk diagnostic utility if you use the Solid State (Flash) drive option. The Flash drive has a limited number of writes to each logical sector. Repeated writes from a diagnostic utility will prematurely shorten the life of the drive.

Reinstalling Operating Systems

The 1506 and 1507 systems ship with MS-DOS preinstalled. Optionally available, are Windows 98, Windows 2000, Windows NT, and Windows XP Professional operating systems. If you want to install a different operating system, refer to that operating system's manual for directions.

Note

If you need to reinstall the Windows 98, Windows 2000, Windows NT, or Windows XP Professional operating system, you must have an internal CD-ROM drive or an external parallel port CD-ROM drive. Windows NT and Windows XP ship only on CD-ROM.

MS-DOS® Reinstallation

If you need to reinstall MS-DOS, refer to the *Xycom Automation Workstation Recovery Media Software Installation Instructions for Microsoft DOS 6.22* (shipped with systems preinstalled with MS-DOS). This document is devoted to the reinstallation of your MS-DOS operating system and drivers utilizing the Recovery Media provided with your Xycom Automation industrial computer.

Note

This procedure assumes that the computer hard disk drive has been completely corrupted or replaced.

Warning

This procedure will destroy data that may exist on the hard disk drive.

Windows® 98 Reinstallation

If you need to reinstall the Windows 98 operating system, refer to the *Xycom Automation Workstation Recovery Media Software Installation Instructions for Microsoft Windows 98* (shipped with systems preinstalled with Windows 98). This document is devoted to the reinstallation of your Microsoft Windows 98 operating system and drivers utilizing the Recovery Media provided with your Xycom Automation industrial computer.

Note

This procedure assumes that the computer hard disk drive has been completely corrupted or replaced.

Warning

This procedure will destroy data that may exist on the hard disk drive.

Windows[®] 2000 Reinstallation

If you need to reinstall the Windows 2000 operating system, refer to the *Xycom Recovery for Xycom Automation Windows 2000 Workstation* (shipped with systems preinstalled with Windows 2000). This document is devoted to the reinstallation of your Windows 2000 operating system and drivers utilizing the Recovery Media provided with your Xycom Automation industrial computer.

Note

This procedure assumes that the computer hard disk drive has been completely corrupted or replaced.

Warning

This procedure will destroy data that may exist on the hard disk drive.

Windows NT[®] Reinstallation

If you need to reinstall the Windows NT operating system, refer to the *Xycom Recovery for Xycom Automation Windows NT Workstation* (shipped with systems preinstalled with Windows NT). This document is devoted to the reinstallation of your Windows NT Workstation 4.0 operating system and drivers utilizing the Recovery Media provided with your Xycom Automation industrial computer.

Note

This procedure assumes that the computer hard disk drive has been completely corrupted or replaced.

Warning

This procedure will destroy data that may exist on the hard disk drive.

Windows XP[®] Reinstallation

If you need to reinstall the Windows XP Professional operating system, refer to the *Windows XP Professional* CD-ROM (shipped with systems preinstalled with Windows XP Professional).

Note

This procedure assumes that the computer hard disk drive has been completely corrupted or replaced.

Warning

This procedure will destroy data that may exist on the hard disk drive.

If you want to install a new operating system or reinstall a current operating system, refer to the operating system's manual for directions.

Installing Drivers

This section describes how to install the drivers associated with the system.

Note

For further assistance, call Xycom Automation technical support at 734-429-4971 ext. 595 or 1-800-AT-XYCOM

Video Drivers

Video drivers and the expansion utilities are on the Documentation and Support Library CD included with the documentation kit.

For the AIM3 system, choose the video driver for your operating system from the following directory on the Documentation and Support Library CD:

\\DRIVERS\\VIDEO\\AIM3 142338

Video Expansion

This section deals with the hardware expansion capability of the video controller chip in DOS applications.

Note

It is *not* necessary to read this section if you are a Windows or OS/2® user and do not plan to run DOS applications.

Unlike a CRT monitor, a flat panel display has a fixed horizontal and vertical resolution. There are many DOS video modes whose resolution is less than that of a flat panel display. In order to more efficiently make use of the flat panel display's active area, it is necessary to employ an expansion technique, which

stretches the lower resolution information to fill the higher resolution of the display.

For example, DOS defaults to VGA video mode 3+. This is an 80 column, 25-row text only screen whose effective resolution is 640 dots x 400 scan lines. Because of this, the 800 x 600 display of the system will be partially filled by the 640 x 400 resolution of this particular mode. The expansion function uses lower resolutions that will better utilize the display by stretching the information in an attempt to fill the display.

Operating systems such as Microsoft Windows 98 and Windows NT use display drivers to handle the different flat panel displays. Here, expansion is not necessary since there is a specific driver for each resolution display.

Expansion does not add any resolution to the existing information; it simply stretches the information to better fit the display. Text and graphic screens can look somewhat grainy from the process of expansion.

Miscellaneous Drivers

Refer to your operating system and peripheral manuals for information on installing drivers related to these items.

Note

If you ordered a system with Windows pre-loaded, you may have to purchase and install an external parallel port CD-ROM drive, or order your system with a CD-ROM drive pre-installed, to be able to install Windows drivers. The Windows operating system ships only on CD-ROM.

Appendix A – Technical Specifications

Hardware Specifications

Table A-1. Hardware Specifications

Characteristic	Specification
Mechanical	1506 1507
	Height 9.24" 9.18"
	Width 11.39" 16.16"
	Depth 5.48" 5.48"
	Weight 13 lbs 18 lbs
Electrical AC	1506 1507
	100-132/200-240 VAC 100-240 VAC 50-60 Hz (switch selectable) 50-60 Hz (auto ranging) 4.0A maximum 5.0A maximum
Power Supply	1506 1507 90 watts 200 watts
Passive Backplane	Four available expansion slots: 1506 1507 one ½ length PCI one ½ length PCI one ¾ length PCI one full length PCI one ¾ length ISA one full length ISA one ¾ length ISA or PCI one full length ISA or PCI
Available Power	With AIM3 CPU board
	1506 1507 +3.3 V 4.0A +3.3 V 10.0A +5 V 5.7A +5 V 12.0A -5 V 160mA -5 V 0.2A +12 V 0.58A +12 V 4.9A -12 V 160mA -12 V 0.5A
	Caution: 1506: +5V and +3.3V not to exceed 28 watts total. -5V and -12V not to exceed 2 watts total. 1507: 3.3V and 5.0V power combined shall not exceed 66 watts.
Agency Approvals	UL 60950 (Recognized) UL 1604 (Listed) cUL CSA C22.2, No. 950 (Recognized) cUL CSA C22.2, No. 213 (Listed)
Regulatory Compliance	FCC 47 CFR, Part 15, Class A CE EMI EN55022, Class A IMMUNITY EN61000-6-2 SAFETY EN60950 HARMONICS EN61000-3-2, Class A FLICKER EN61000-3-3

Environmental Specifications

Table A–2. Environmental Specifications

Characteristic	Specification
Temperature	
Operating	0° to 50° C (32° to 122° F)
Non-operating	-20° to 60°C (-4° to 140°F)
Humidity	
Operating	20% to 80% RH, noncondensing
Non-operating	20% to 80% RH, noncondensing
Altitude*	
Operating	Sea level to 10,000 feet (3,048 m)
Non-operating	Sea level to 40,000 feet (12,192 m)
Vibration (5 to 2000 Hz)	
Operating**	0.006" (0.15mm) peak to peak displacement 1.0g maximum acceleration
Non-operating	0.015" (0.38mm) peak to peak displacement 2.5g maximum acceleration
Shock	
Operating**	15g peak acceleration, 11 msec duration, ½ sine wave
Non-operating	30g peak acceleration, 11 msec duration, ½ sine wave

* Consistent with internal component specifications

** These values are with solid-state hard drives and not rotating media drives.

Appendix B – AC Model Block Diagram

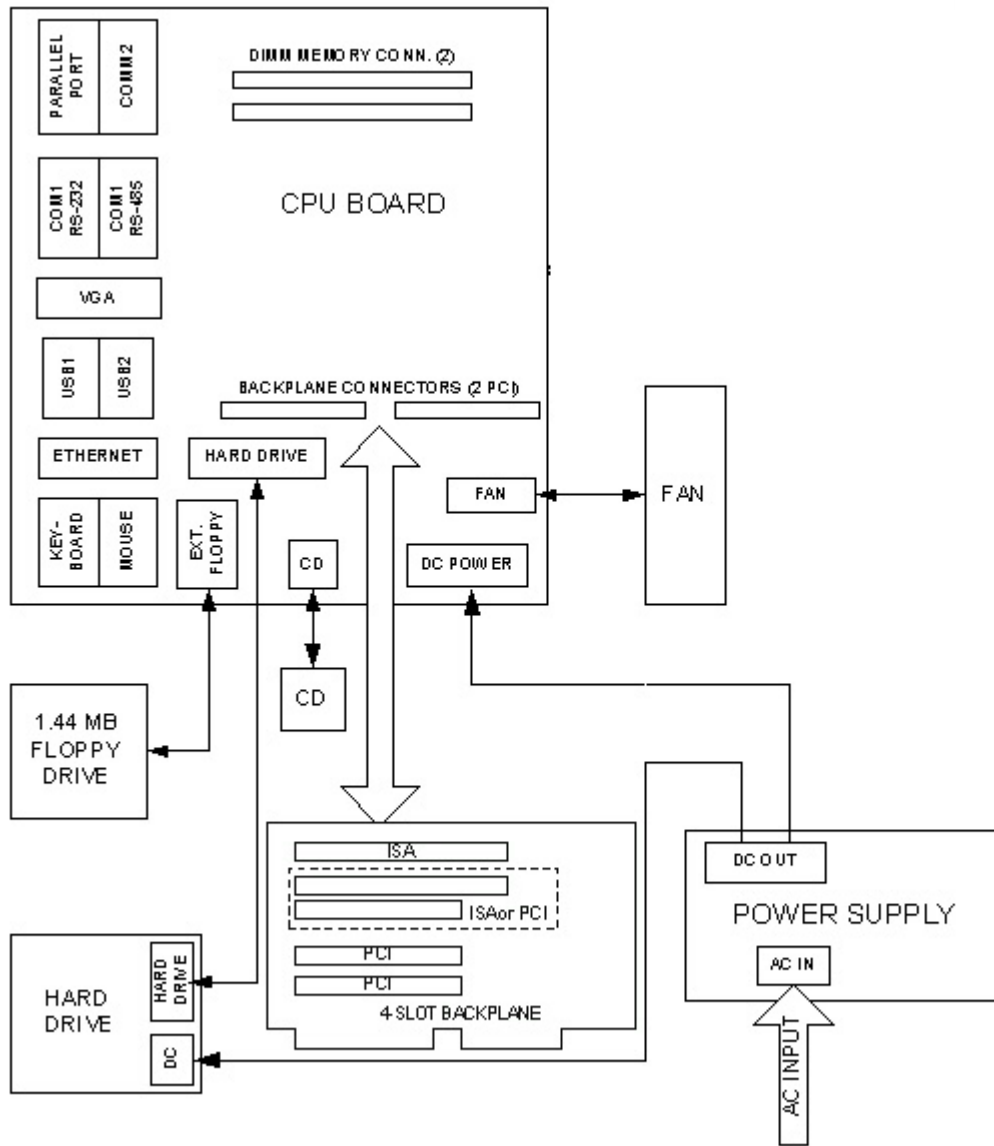

Figure B-1. 1506/1507 System Block Diagram

Appendix C – Pinouts

This appendix provides the pinouts for the keyboard, mouse, LPT1, COM1, COM2, USB, and VGA connectors. **NC indicates No Connection.**

Keyboard Port Connector

This connector is a standard PS/2-compatible connector.

Table C-1. Keyboard Connector Pinout

Pin	Signal
1A	KB_DATA
2A	NC
3A	GND
4A	5VFUSE
5A	KB_CLK
6A	NC

Mouse Port Connector

This PS/2 mini-DIN connector allows you to attach a mouse.

Table C-2. Mouse Connector Pinout

Pin	Signal
1B	MOUSE_DATA
2B	NC
3B	GND
4B	5VFUSE
5B	MOUSE_CLK
6B	NC

Dual USB Connector (USB1)

Table C–3. Dual USB Pinout

Pin	Description	Pin	Description
1A	5VFUSE	1B	5VFUSE
2A	USBP0–	2B	USBP1–
3A	USBP0+	3B	USBP1+
4A	GND	4B	GND

Parallel Port Connector (LPT1)

This is a 25-pin DB connector.

Table C–4. Parallel Connector Pinout

Pin	Signal	Pin	Signal
1	STROBE	14	AUTOFEED
2	PD(0)	15	PERROR
3	PD(1)	16	INIT
4	PD(2)	17	SELIN
5	PD(3)	18	GND
6	PD(4)	19	GND
7	PD(5)	20	GND
8	PD(6)	21	GND
9	PD(7)	22	GND
10	PACK	23	GND
11	PBUSY	24	GND
12	PE	25	GND
13	SELECT		

Serial Port Connectors

Serial ports RS-232 and RS-485 are supported. Only one connector can be used at a time. All termination is done outside the unit. Refer to the AIM3 manual for different RS-485 connectors.

COM1

Table C-5. COM1 Connector Pinout

RS-232		RS-485	
Pin	Signal	Pin	Signal
1A	DCD1	1B	TXD –
2A	RXD1	2B	TXD+
3A	TXD1	3B	TXD TERM –
4A	DTR1	4B	TXD TERM +
5A	GND	5B	GND
6A	DSR1	6B	RXD –
7A	RTS1	7B	RXD +
8A	CTS1	8B	RXD TERM +
9A	RI1	9B	RXD TERM –

Technical Note

For TXD termination, connect a 150 Ω , ½ watt resistor from pin 3B to pin 4B, with pin 1B connected to pin 3B and pin 2B connected to pin 4B.

For RXD termination, connect a 150 Ω , ½ watt resistor from pin 8B to pin 9B, with pin 6B connected to pin 9B and pin 7B connected to pin 8B.

COM2

Table C-6. COM2 Connector Pinout

RS-232			
Pin	Signal	Pin	Signal
1	ORB_GND	14	NC
2	TXD2	15	NC
3	RXD2	16	NC
4	RTS2	17	NC
5	CTS2	18	NC
6	DSR2	19	NC
7	GND	20	DTR2
8	DCD2	21	NC
9	NC	22	RI2
10	NC	23	NC
11	PB_RESET	24	NC
12	NC	25	NC
13	NC		

VGA Connector

The VGA connector is a 15-pin connector.

Table C-7. VGA Connector Pinout

Pin	Signal	Pin	Signal
1	RED	9	Fused VCC
2	GREEN	10	ORB_GND
3	BLUE	11	NC
4	NC	12	DDCDAT
5	ORB_GND	13	HSYNC
6	ORB_GND	14	VSYNC
7	ORB_GND	15	DDCCLK
8	ORB_GND		

APPENDIX D – AIM3 CONTROLLER JUMPERS

Table D-1. Controller Jumpers

Jumper	Position	Function
JP1 JP2 JP3 JP4		Not used – Not stuffed
JP6	1-2 2-3 √	Provide ground return for +12V/+5V on COM2 connector Do not provide ground return for +12V/+5V on COM2 connector
JP7	1-2 √ 2-3	Allow high side alarm function on COM2 connector Do not allow high side alarm function on COM2 connector
JP8	1-2 √ 2-3	Allow low side alarm function on COM2 connector Do not allow low side alarm function on COM2 connector
JP9	1-2 2-3 √	Supply +12V to COM2 connector Do not supply +12V to COM2 connector
JP10	1-2 2-3 √	Supply +5V to COM2 connector Do not supply +5V to COM2 connector
JP11	1-2 2-3 √	Allow external reset from COM2 connector Do not allow external reset from COM2 connector
JP12	1-2 2-3 √	BIOS detects 40 cond cable (UDMA33 max) Primary IDE BIOS detects 80 cond cable (UDMA66/100 max) Primary IDE
JP13	1-2 √ 2-3	BIOS detects 40 cond cable (UDMA33 max) Secondary IDE BIOS detects 80 cond cable (UDMA66/100 max) Secondary IDE
JP14	1-2 2-3 √	CD-ROM is master on primary IDE CD-ROM is slave on primary IDE
JP15	1-2 √ 2-3	Normal operation Clear CMOS
JP16		This is not a jumper. It allows Arium Emulator to reset the board.

√ indicates default jumper setting

Index

AIM3	
jumpers	45
Cable	
communication cable interface	26
connections	26
Class I locations	23
Class II locations	24
COM ports	9
COM1 connector	43
Connectors	
AIM3+	
COM1	43
parallel port	42
VGA	44
keyboard	41
mouse	41
Definitions	
class and division	23
DIMM	11
Division 1 locations	24
Division 2 locations	24
Documentation kit	2
DRAM	11
Drivers	
installing	36
miscellaneous	37
video	36
Dual Inline Memory Modules	11
Enclosures	25
Fan	28
filter replacement	28
Features	
standard	1
Front panel	4
Fuse	
replacement	28
Groups	25
Heat, excessive	13
Installation	
DRAM	11
driver	36
hazardous locations	21
internal hardware	10
mounting considerations	12
of system into a panel	12
operating systems	34
PC/AT and PCI boards	11
Jumper settings	
AIM3 CPU board	45
Keyboard	
connectors	41
Keyboard port	9
Line voltage, variation	14
Maintenance	28
general	28
hard drive	29
mounting	17
dimensions	18
Mounting the unit	12
Mouse port	9, 41
Noise, electrical	14
Operating systems	
installation	34
Parallel port connector	42
PC/AT installation and PCI boards	11
Pinouts	
COM1	43
COM2	43
keyboard connector	41
mouse connector	41
parallel port	42
VGA connector	44
Ports	
COM	9

keyboard	9, 41
mouse	9, 41
parallel	9, 42
printer.....	9
serial	9
video	9
Power	
system.....	13
Power supply	16
Power switch.....	25
Preparing the system	10
Preventive maintenance	28
general	28
hard drive	29
Printer port	9
Repairs and service	30
Safety agency approval	22
Serial port connectors	43
Serial ports.....	9
Service and repairs	30
System	
maintenance	26
operation	26
System components	
Front panel.....	4
System Power.....	13
VGA connector.....	44
Video drivers	36
Video expansion	36
Video port.....	9

143095 (A)

Xycom™ Automation, Inc.
734-429-4971
Fax: 734-429-1010
<http://www.Xycom.com>

Canada Sales: 905-607-3400
Northern Europe Sales: +44-1604-790-767
Southern Europe Sales: +39-011-770-53-11

