

5019T

Flat Panel Industrial Touch Monitor

User Manual

<i>Revision</i>	<i>Description</i>	<i>Date</i>
A	Manual Released	09/04

Part Number 143627 (A)***Trademark Information***

Brand or product names are trademarks or registered trademarks of their respective owners. Intel and Pentium are registered trademarks and Celeron is a trademark of Intel Corporation. Windows, Windows NT, and Windows XP are registered trademarks of Microsoft Corporation in the U.S. and in other countries.

Copyright Information

This document is copyrighted by Xycom Automation Incorporated (Xycom Automation) and shall not be reproduced or copied without expressed written authorization from Xycom Automation.

The information contained within this document is subject to change without notice. Xycom Automation does not guarantee the accuracy of the information.

United States FCC Part 15, Subpart B, Class A EMI Compliance Statement:

NOTE: This equipment has been tested and found to comply with the limits for a Class A digital device, pursuant to part 15 of the FCC Rules. These limits are designed to provide reasonable protection against harmful interference when the equipment is operated in a commercial environment. This equipment generates, uses, and can radiate radio frequency energy and, if not installed and used in accordance with the instruction manual, may cause harmful interference to radio communications. Operation of this equipment in a residential area is likely to cause harmful interference in which case the user will be required to correct the interference at his or her own expense.

WARNING – European Users:

This is a Class A product. In a domestic environment this product may cause radio interference in which case the user may be required to take adequate measures.

INSTALLATION: *Electromagnetic Compatibility WARNING*

The connection of non-shielded equipment interface cables to this equipment will invalidate FCC EMI and European Union EMC compliance and may result in electromagnetic interference and/or susceptibility levels which are in violation of regulations which apply to the legal operation of this device. It is the responsibility of the system integrator and/or user to apply the following directions, which relate to installation and configuration:

All interface cables must include shielded cables. Braid/foil type shields are recommended. Communication cable connectors must be metal, ideally zinc die-cast backshell types, and provide 360-degree protection about the interface wires. The cable shield braid must be terminated directly to the metal connector shell, ground drain wires alone are not adequate.

Protective measures for power and interface cables as described within this manual must be applied. Do not leave cables connected to unused interfaces or disconnected at one end. Changes or modifications to this device not expressly approved by the manufacturer could void the user's authority to operate the equipment.

Table of Contents

CHAPTER 1 – INTRODUCTION	2
PRODUCT OVERVIEW	2
<i>Standard Features</i>	2
<i>Optional Features</i>	2
<i>Front Panel Controls</i>	3
<i>I/O Panel</i>	4
UNPACKING THE UNIT	5
QUICK STARTUP	5
CHAPTER 2 – INSTALLATION	6
INSTALLATION OVERVIEW	6
PRODUCT DIMENSIONS.....	8
<i>5019T Dimensions</i>	8
POWER MANAGEMENT.....	9
<i>System Power</i>	9
<i>Excessive Heat</i>	10
<i>Electrical Noise</i>	11
<i>Line Voltage Variation</i>	11
HAZARDOUS LOCATIONS INSTALLATIONS	12
<i>Definitions</i>	13
<i>Power Switch</i>	15
<i>Cable Connections</i>	15
<i>Operation and Maintenance</i>	16
<i>Safety Agency Approval</i>	17
MOUNTING OPTIONS	17
<i>Panel Installation</i>	17
<i>VESA Arm Mounting</i>	19
CHAPTER 3 – MONITOR SETTINGS	20
ON-SCREEN DISPLAY (OSD) SWITCH	20
MODE AND IMAGE ADJUSTMENT	20
<i>Reset Factory Default Settings</i>	25
ANALOG RGB INTERFACE SPECIFICATIONS	25
VIDEO MODES	25
CHAPTER 4 – OPERATOR INPUT	26
INSTALLING THE TOUCH SCREEN DRIVER	26
CALIBRATING THE TOUCH SCREEN.....	26
ACCESSING THE “MOUSE RIGHT BUTTON” FUNCTIONALITY WITH THE TOUCH SCREEN	27
USING A POINTING DEVICE WITH A TOUCH SCREEN FOR DOS	27
CHAPTER 5 – HARDWARE	28
VGA INPUT CONNECTOR.....	28
DVI-D INPUT CONNECTOR	29
COMPOSITE VIDEO AND S-VIDEO INPUT	29
SERIAL INTERFACE.....	29
<i>Touch Screen RS-232 Output Connector</i>	30
<i>Touch Screen USB Output Connector</i>	30
APPENDIX A – TECHNICAL SPECIFICATIONS	32
HARDWARE SPECIFICATIONS.....	32
ENVIRONMENTAL SPECIFICATIONS	33
APPENDIX B – TECHNICAL SUPPORT	34
BEFORE CONTACTING TECHNICAL SUPPORT.....	34
CONTACTING TECHNICAL SUPPORT	34
PRODUCT REPAIR PROGRAM	35

Chapter 1 – Introduction

Product Overview

Xycom Automation industrial flat panel touch monitors offer state-of-the-art performance and features while meeting the rigorous requirements of the plant floor. Xycom's 5019T high-resolution flat panel display is contained within a rugged housing with a resistive membrane touch screen.

Standard Features

- 19" Flat Panel TFT SXGA supporting resolutions up to 1280 x 1024
- 2.85" mounting depth
- Five-wire analog resistive touch screen with either RS-232 or USB interfaces
- Front panel controls for on-screen menus with lock-out switch on rear of units (for units with aluminum bezel)
- NEMA 4/4x/12 front panel (when properly mounted)
- DVI, 15-pin analog, S-video, and Composite video inputs

Optional Features

- 24V DC input power
- Stainless steel front bezel, with rear panel controls for on-screen menus and lock-out switch
- No touch screen installed

Caution

Leaving your TFT LCD display on constantly can result in temporary image retention (TIR). TIR can be avoided by using a screen saver, enabling the idle/doze timeout feature, or by turning off the display when it is not in use.

Front Panel Controls

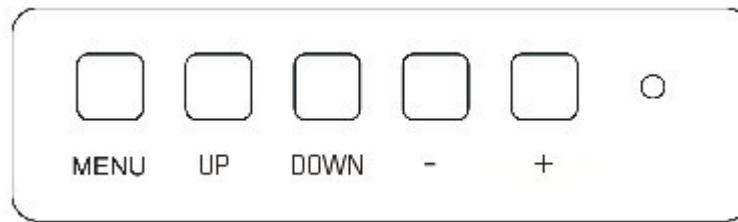

Figure 1-1. 5019T Front Panel Controls

Table 1-1. 5019T Front Panel Controls Functions

Feature	Description
Menu	This button is used to open and select options in the On Screen Display (OSD) menu.
Up	This button moves the selector up on the menu or adjustment bar.
Down	This button moves the selector down on the menu or adjustment bar.
-	This button moves the selector left in the menu or on adjustment bar.
+	This button moves the selector right in the menu or on adjustment bar.

I/O Panel

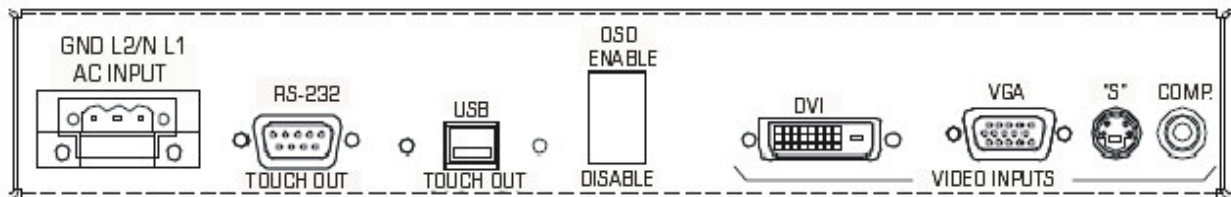

Figure 1-2. 5019T I/O Panel

Warning

To maintain a safe condition, do not use the USB, S-Video and/or Composite Video ports when the unit is operating in the presence of a hazardous environment.

Table 1-2. 5019T I/O Panel Functions

Feature	Description
AC Input	100-240 VAC auto-ranging (18-30 V DC on DC models)
Touch output to computer	One of the two following options will be available on units ordered with the touch option. (Please note that if you do not order the touch option, neither touch output option will be available.)
Touch Out USB	Touch screen output on USB models
Touch Out RS-232	Touch screen output on RS-232 models
OSD Selector Switch	Used to enable or disable (lock) adjustment buttons on front of monitor
Video Inputs	The 5019T monitor has four video input options: Digital Video Input (DVI), a DVI-D connector, for digital signal input to an analog monitor; VGA Input (VGA), to connect this VGA monitor for standard analog input from a computer; S Video Input (S), a super-video connector, for video signal transmission where the image data parts are separated; Composite Video Input (COMP.), for enhanced video signal transmission where the image data is combined during transmission.

Unpacking the Unit

When you remove the 5019T from its shipping box, verify that you have the parts listed below. Save the box and inner wrapping in case you need to reship the unit.

- 5019T unit
- Installation Fasteners (16)
- Cables:
 - VGA cable, 10 ft. (3 m), and
 - RS-232C Cable, 10 ft. (3 m) for RS-232C touch option, or
 - USB Cable, 10 ft. (3 m) for USB touch option
 - Ground strap
- Documentation and Support Library CD-ROM, which contains this manual and all drivers required by this unit.

Quick Startup

This section gives you the steps to get the system up and running without explaining the capabilities and options.

Warning

Remove power from the unit and disconnect the power cord before making any adjustments to the inside or outside of the monitor.

Warning

For Hazardous Locations installation, review *Hazardous Locations Installation* in Chapter 2 before startup.

To prepare the system for use, perform the following steps.

1. Attach the appropriate touch cable (USB or RS-232) if your monitor was ordered with the touch option, following the instructions in Chapter 2.
2. Attach the power cord from the power receptacle to a properly grounded 100-240 V AC, 50-60 Hz, or an optional 18-30 V DC power source. (See *System Power* in Chapter 2 for more information.)
3. Turn on power to the 5019T (via an outlet power switch if applicable). Then turn on power to the host computer. The system will boot up into the operating system.
4. If the unit is equipped with a touch screen, install drivers on the host computer via the floppy, the CD-ROM, or the network, as applicable.

Chapter 2 – Installation

Installation Overview

The design of the 5019T allows the unit to be installed in most industrial environments. The system is generally placed in a NEMA 4/4X/12 enclosure to protect against contaminants such as dust and moisture. Class II Hazardous Locations always require a Type 12 (dust-proof) minimum enclosure rating.

Read the following sections carefully to be sure that you are complying with all the safety requirements.

1. Select a NEMA rated enclosure and place the unit within the enclosure to allow easy access to the system ports (see other sections in this chapter and Appendix A).
 - To assure a NEMA 4 seal, choose an approved enclosure that has a 14-gauge (0.075 in/1.9 mm thick steel or 0.125 in/3.2 mm thick aluminum) front face.
 - Be sure to account for the unit's depth when choosing the depth of the enclosure.
2. Create a cutout in the enclosure (see Figure 2-2).
3. Be sure to place the unit at a comfortable working level
4. Make sure the area around the cutout is clean and free from metal burrs
5. Mount the unit in an upright position and properly secure the unit into the panel.
6. Attach one end of the power cord to the power receptacle on the unit and the other end to a properly grounded 100-240 VAC, 50-60 Hz outlet, or optional 18-30 VDC power source.
 - When using the USB touch interface option, you must also attach the ground strap cable to one of the three 6-32 mounting screws on the back cover of the 5019 and connect the other end of the cable to the Protective Earth ground.
7. Turn on power to the 5019T unit. Then turn on power to the host computer. The system will boot up into the operating system.
8. Install the application software on the host computer via a floppy drive, CD-ROM, or the network.

Additional aspects to take into account when mounting your 5019T unit:

- Consider locations of accessories such as AC power outlets and lighting (interior lighting and windows) for installation and maintenance convenience
- Prevent condensation by installing a thermostat-controlled heater or air conditioner
- To allow for maximum cooling, avoid obstructing the airflow
- Place any fans or blowers close to the heat generating devices. If using a fan, make sure that outside air is not brought into the enclosure unless a fabric or other reliable filter is used. This filtration prevents conductive particles and other harmful contaminants from entering the enclosure.
- Do not select a location near equipment that generates excessive electromagnetic interference (EMI) or radio frequency interface (RFI). Examples of these types of equipment are: high power welding machines; induction heating equipment; and large motor starters.
- Place incoming power line devices (such as isolation or constant voltage transformers, local power disconnects, and surge suppressers) away from the system. The proper location of incoming line devices keeps power wire runs as short as possible and minimizes electrical noise transmitted to the unit.
- Make sure the location does not exceed the unit's shock, vibration, and temperature specifications
- Install the unit in the rack or panel in such a way as to ensure that it does not cause a hazard from uneven mechanical loading

Product Dimensions

5019T Dimensions

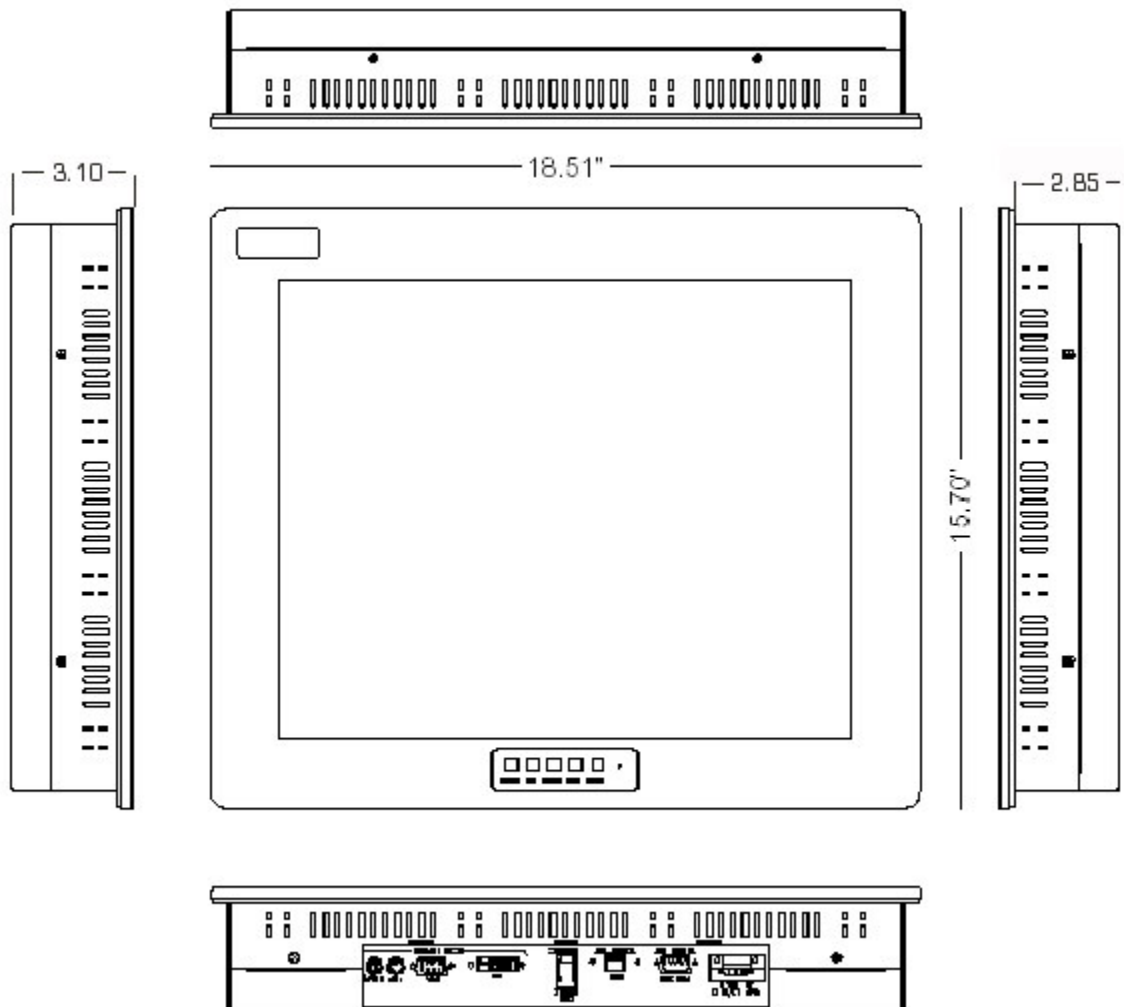

Note: All dimensions are in inches.

Figure 2-1. 5019T Dimensions

Power Management

The monitor is based on the VESA DPMS and the DVI DMPM standards. To activate the monitor's Power Management function, both the video controller and the computer **must** conform to the VESA DPMS standard and the DVI DMPM standard.

System Power

It is a good practice to use isolation transformers on the incoming AC power line to the system. An isolation transformer is especially desirable in cases in which heavy equipment is likely to introduce noise onto the AC line. The isolation transformer can also serve as a step-down transformer to reduce the incoming line voltage to a desired level. The transformer should have a sufficient power rating (units of volt-amperes) to supply the load adequately.

Proper grounding is essential to all safe electrical installations. Refer to the relevant federal, state/provincial, and local electric codes, which provide data such as the size and types of conductors, color codes and connections necessary for safe grounding of electrical components. The code specifies that a grounding path must be permanent (no solder), continuous, and able to safely conduct the ground-fault current in the system with minimal impedance (minimum wire required is 18 AWG, 1 mm).

Observe the following practices:

- Separate the power and ground (P. E., or Protective Earth) cable from signal cables.
- All electrical racks or chassis and machine elements should be Earth Grounded in installations where high levels of electrical noise can be expected. The rack/chassis should be grounded with a ground rod or attached to a nearby Earth structure such as a steel support beam. Connect each different apparatus to a single Earth Ground point in a "star" configuration with low impedance cable. Scrape away paint and other nonconductive material from the area where a chassis makes contact with the enclosure.
- To maintain CE compliance when using the USB touch interface option, a ground strap cable must be attached to the back of the 5019 chassis to earth-ground the unit. See the Installation Instructions for directions on how to attach this cable.

Power Terminal Block

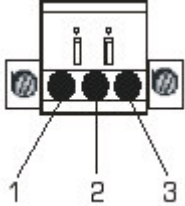
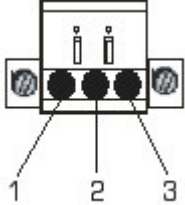
<p>100-240 VAC Power Input Terminal Block</p> 	Number	<i>Function</i>
	1	AC Line Input
	2	AC Neutral Input
	3	Protective Earth Ground
<p>18-30 VDC Power Input Terminal Block</p> 	Number	<i>Function</i>
	1	+ DC Line Input
	2	- DC Return Input
	3	Protective Earth Ground

Caution:

Use AWG18 wire or greater for the 5019T's power cable.

Isolate the AC main circuit line, I/O signal lines, and power cord - do not bind or group them together.

Excessive Heat

To keep the temperature in range, the cooling air at the base of the system must not exceed the maximum temperature specification (see *Environmental Specifications* on page 33). Allocate proper spacing between internal components installed in the enclosure. When the air temperature is higher than the specified maximum in the enclosure, use a fan or air conditioner to lower the temperature.

Electrical Noise

Electrical noise is seldom responsible for damaging components, unless extremely high energy or high voltage levels are present. However, noise can cause temporary malfunctions that can result in hazardous machine operation in certain applications. Noise may be present only at certain times, may appear at widely spread intervals, or in some cases may exist continuously.

Noise commonly enters through input, output, and power supply lines and may also be coupled through the capacitance between these lines and the noise signal carrier lines. This usually results from the presence of high voltage or long, close-spaced conductors. When control lines are closely spaced with lines carrying large currents, the coupling of magnetic fields can also occur. Use shielded cables to help minimize noise. Potential noise generators include switching components, relays, solenoids, motors, and motor starters.

Refer to the relevant Federal, State/Provincial, and local electric codes, which provide data such as the size and types of conductors, color codes and connections necessary for safe grounding of electrical components. It is recommended that high- and low-voltage cabling be separated and dressed apart. In particular, AC cables and switch wiring should not be in the same conduit with all communication cables.

Line Voltage Variation

The power supply section of the unit is built to sustain the specified line fluctuations and still allow the system to function in its operating margin. As long as the incoming voltage is adequate, the power supply provides all the logic voltages necessary to support the monitor unit.

Unusual AC line variations may cause undesirable system shutdowns. As a first step to reduce line variations, correct any possible feed problems in the distribution system. If this correction does not solve the problem, use a constant voltage transformer. The constant voltage transformer stabilizes the input voltage to the systems by compensating for voltage changes at the primary in order to maintain a steady voltage at the secondary. When using a constant voltage transformer, check that the power rating is sufficient to supply the unit.

Hazardous Locations Installations

Xycom Automation designed the 5019T monitor with the intention of meeting the requirements of Class I, Division 2 Hazardous Locations applications. Division 2 locations are those locations that are normally non-hazardous, but potentially hazardous should an accident expose the area to flammable vapors, gases or combustible dusts.

These systems are non-incendiary devices. They are not intrinsically safe and should never be operated within a Division 1 (normally hazardous) location when installed as described here. Nor should any peripheral interface device attached to these systems be located within Division 1 locations unless approved and/or certified diode barriers are placed in series with each individual signal and DC power line. Any such installations are beyond the bounds of Xycom Automation design intent. Xycom Automation accepts no responsibility for installations of this equipment or any devices attached to this equipment in Division 1 locations.

It is the responsibility of the customer to ensure that the product is properly rated for the location. If the intended location does not presently have a Class, Division, and Group rating, then users should consult the appropriate authorities having jurisdiction in order to determine the correct rating for that Hazardous Location.

In accordance with Federal, State/Provincial, and Local regulations, all hazardous location installations should be inspected by the appropriate authority having jurisdiction prior to use. Only technically qualified personnel should install, service, and inspect these systems.

Warning

Suitable for use in Class I, Division 2 Groups A, B, C, and D, and Class II, Division 2, Groups F and G hazardous locations or non-hazardous locations only.

Warning - Explosion Hazard

Substitution of components may impair suitability for Class I, Class II, Division 2.

Advertisement Risque D' Explosion

La substitution de composants peut rendre ce matériel inacceptable pour les emplacements de classe I, II, Division 2.

Warning - Explosion Hazard

Do not disconnect equipment unless the power has been switched off or the area is known to be non-hazardous.

Advertissement Risque D' Explosion

Avant de deconnecter l'equipement, coupler le courant ou s'assurer que l'emplacement est designe non dangereux.

Warning - Explosion Hazard

When in hazardous locations, turn off power before replacing or wiring modules.

Advertissement Risque D' Explosion

Dans les situations hasardees, couper la courant avant de remplacer ou de cabler les modules.

Warning

To maintain a safe condition, do not use an external keyboard or mouse or USB port devices when the unit is operating in a hazardous environment.

Definitions

The following Class and Division explanations are derived from Article 500 (Sections 5 and 6) of the United States National Fire Protection Agency National Electric Code (NFPA 70, 1990). They are not complete and are included here only for a general description for those not familiar with generic hazardous locations' requirements.

Persons responsible for the installation of this equipment in Hazardous Locations are responsible for ensuring that all relevant codes and regulations related to location rating, enclosure, and wiring are met.

Class I Locations

Class I locations are those in which flammable gases or vapors are or may be present in the air in quantities sufficient to produce explosive or ignitable mixtures.

Class II Locations

Class II locations are those that are, or may become, hazardous because of the presence of combustible dust.

Division 1 Locations

A Division 1 location is one in which flammable or ignitable gasses, vapors, or combustible dusts and particles can exist due the following conditions:

- Normal operating conditions.
- Because of repair, maintenance conditions, leakage, or where mechanical failure or abnormal operation of machinery or equipment might release or cause explosive or ignitable mixtures to be released or produced.
- Combustible dusts of an electrically conductive nature may be present in hazardous quantities.

Note

Xycom Automation 5019T, 5019T-24V systems are not suitable for installation within Division 1 locations.

Note

Electrical equipment cannot be installed in Division 1 locations unless they are intrinsically safe, installed inside approved explosion-proof enclosures, or installed inside approved purged and pressurized enclosures.

Division 2 Locations

- Class I volatile flammable liquids or flammable gasses are handled, processed, or used, but confined within closed containers or closed systems from which they can escape only in cases of accidental rupture or breakdown of such enclosures or systems, or in case of abnormal operation of equipment.
- Ignitable concentrations of Class I vapors or gasses are normally prevented by positive mechanical ventilation, but which may become hazardous due to mechanical failure of those ventilation systems.
- Location is adjacent to a Division 1 location.
- Class II combustible dust is not normally in the air in quantities sufficient to produce explosive or ignitable mixtures. Dust accumulations are normally insufficient to interfere with normal operation of electrical equipment or other apparatus. Combustible dust may be in suspension in the air as a result of the following: infrequent malfunctioning of handling or processing equipment; combustible dust accumulations on, or in the vicinity of electrical equipment; may be ignitable by abnormal operation or failure of electrical equipment.

Groups

All electrical equipment that is approved for use in hazardous locations must include a group rating. Various flammable and combustible substances are divided into these groups as a function of their individual maximum experimental safe gap (MESG), explosion pressure, and ignition temperature.

Component temperatures and the potential for spark based upon voltage, current, and circuit characteristics, within electrical equipment, will determine what the equipment group rating will be. A device approved for installation within Class I, Group A locations may also be used in Groups B, C, or D.

Note

Approved Class I equipment may not be suitable for Class II installations. Class I includes Groups A, B, C, and D. Class II includes Groups F, and G.

Power Switch

The systems do not have a power switch. The amount of input power required by these systems classifies a power switch as an incendiary device because the voltage and current across the make/break device are capable of creating a spark.

Hazardous locations' regulations require that a power switch rated for ordinary locations may be used if it is located in an area specified as non-hazardous. However, limits in cable length between the workstation and the power switch may apply. Otherwise the switch must be compliant with Class I, Division 1 requirements (intrinsically safe). These switches are built in a manner that prevents the possibility of a spark when contacts are made or broken.

Use suitable UL listed and/or CSA Certified Class I, Division 1 switches in hazardous locations. These switches are available from a wide number of sources. It is the responsibility of the customer to ensure that the power switch selected for their installation has the correct hazardous locations rating for the location in which it is installed.

Cable Connections

Division 2 hazardous locations' regulations require that all cable connections be provided with adequate strain relief and positive interlock. USB connections can never be used in hazardous location installations, because USB connectors do not provide adequate strain relief. Never connect or disconnect a cable while power is applied at either end of the cable.

All communication cables should include a chassis ground shield. This shield should include both copper braid and aluminum foil. The D-sub style

connector housing should be a metal conductive type (e.g., molded zinc) and the ground shield braid should be well terminated directly to the connector housing. Do not use a shield drain wire.

The outer diameter of the cable must be suited to the inner diameter of the cable connector strain relief in order to ensure that a reliable degree of strain relief is maintained.

Warning

Never connect or disconnect the communication cables while power is applied at either end of the cable. This may result in an incendiary spark. Permanent damage to the workstation communication components may occur.

Operation and Maintenance

The systems have been designed for compliance with relevant spark ignition tests. However, please note that the workstation front panel contrast adjustment tactile switches and keyboard connector are the only make/break components intended to be exercised by the operator in the course of normal operation.

Warning

To maintain a safe condition, never use an external keyboard or mouse or USB port devices when the unit is operating in a hazardous environment.

Always observe the following rules with respect to hazardous location installations:

1. Always install the 5019T monitor within an enclosure suitable for the specific application. General-purpose enclosures may be acceptable for Class I applications but are never acceptable for Class II applications. Type 4 (IP 65) enclosures are recommended even when not required by regulations.
2. If present, keep enclosure doors or openings closed at all times, to avoid the accumulation of foreign matter inside the workstation.
3. Never subject the unit to any installation or service procedures unless power is removed and the area is known to be non-hazardous. This includes the installation or removal of power cables, communication cables, or removal of the rear cover of the unit.

Only technically qualified service personnel should perform all installation and service. These workstations are designed to require no service in the course of normal operation by an operator.

Safety Agency Approval

The Xycom Automation systems are designed to meet the following standards:

- Underwriters Laboratories Inc., UL 1604 Standard for Safety Electrical equipment for use in Class I and Class II, Division 2, locations
- Underwriters Laboratories Inc., UL 508, Information Technology Equipment
- Canadian Standard Association, Specification C22.2 No. 213-M1987 Non-incendiary electrical equipment for use in Class I, Division 2 hazardous locations
- Canadian Standards Association, Specification C22.2 No. 142 Information Technology Equipment
- EN 60950, Information Technology Equipment

Mounting Options

The 5019T can be mounted in a panel or to an arm. The following sections describe the two mounting options.

Panel Installation

The 5019T monitor should be mounted and used where NEMA 4 and NEMA 12 type enclosures are employed. When mounted properly, the monitor meets or exceeds the sealing requirements set forth in the NEMA 4 and NEMA 12 specifications. The monitor uses "U"-shaped clips and a special gasket to achieve the proper seal.

Make a cutout in one of the walls of your NEMA enclosure (see Figure 2-2 for cutout dimensions). Enclosures made of heavier gauge metal work better in that they won't deform or bend as easily when the monitor's sealing gasket is compressed.

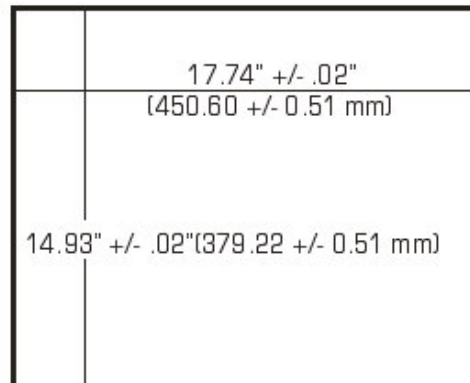

Figure 2-2. 5019T Cutout Dimensions

The 5019T has 16 total mounting clips: 4 mounting clips each on the top, bottom and both of the sides of the monitor. Hold the monitor in place while you install the mounting clips (see Figure 2-3 for mounting clip locations). Tighten the clips in a crisscross pattern. This will help to develop an even pressure on the sealing gasket. Tighten the clips until the back of the monitor's front bezel begins to contact the front of the NEMA enclosure (at least 7 in-lbs of torque).

Caution

Over-tightening the clips can cause damage to the monitor, which can result in loss of seal integrity.

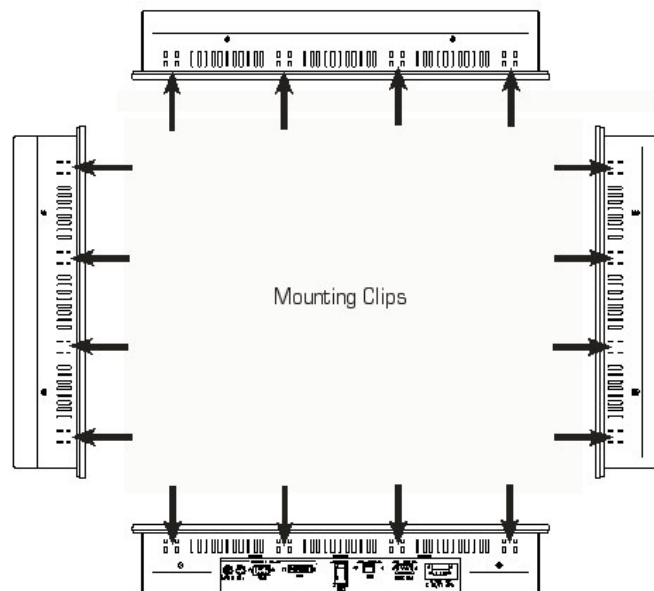

Figure 2-3. Mounting Clip Locations

Insert the hook section into the slots and tighten the fastener with a screwdriver, as shown.

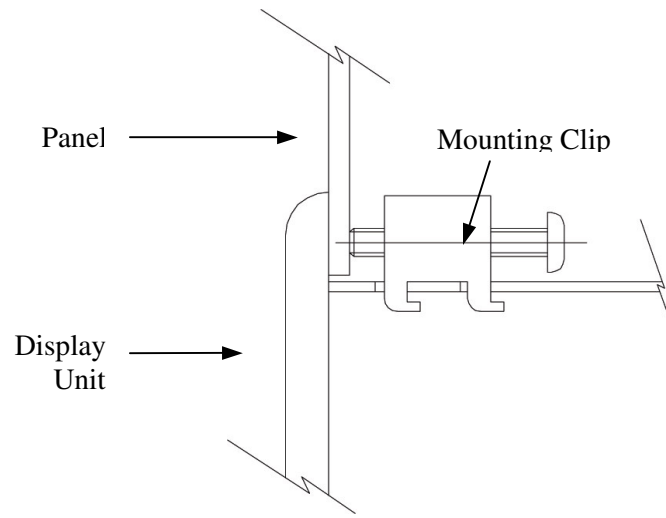

Figure 2-4. Fastening the Monitor to the Panel

VESA Arm Mounting

Your 5019T monitor also accommodates 100mm interface pads for VESA arm mounting. Figure 2-5 gives the dimensions for arm mounting.

Please note that there are 3 sets of mounting holes on the back of the 5019T monitor: one for mounting the monitor on a 100 mm VESA arm; one for attaching a Xycom Automation 1506 Node PC to the monitor; and one for attaching a Xycom Automation 1300 Thin Client PC to the monitor. Refer to the respective user manual for instructions on mounting the 1506 Node PC (using 10/32" machine screws) or the 1300 Thin Client PC (using 6/32" machine screws).

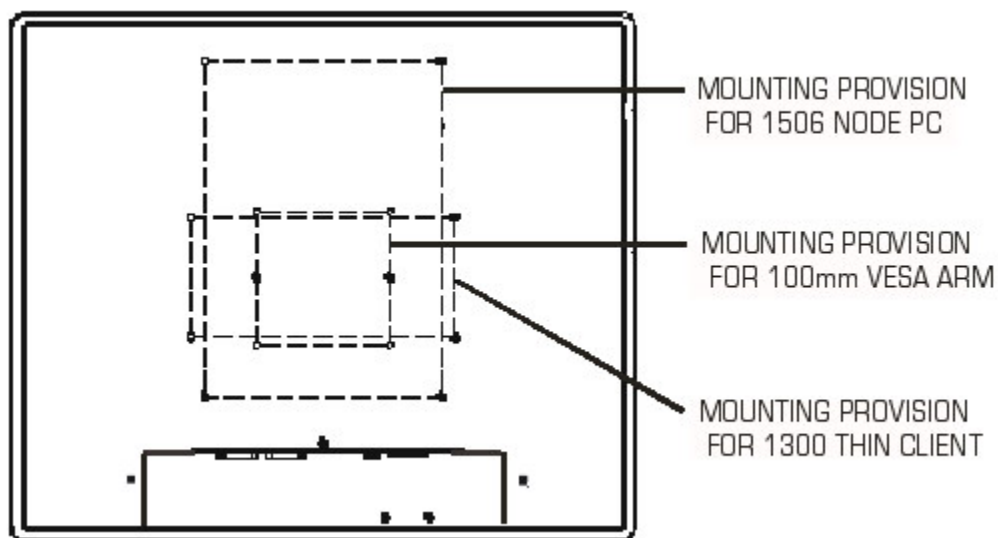

Figure 2-5. VESA Arm mounting diagram

Chapter 3 – Monitor Settings

Caution

Leaving your TFT LCD display on constantly can result in temporary image retention (TIR). TIR can be avoided by using a screen saver, enabling the idle/doze timeout feature, or by turning off the display when it is not in use.

On-Screen Display (OSD) Switch

The OSD Select switch is located on the I/O panel (see Figure 1-2) and offers two choices: enable or disable. The keys on the front of the monitor can be locked-out by setting the OSD switch to disable, or unlocked by setting the OSD switch to enable.

Caution

Please use the OSD after confirming the position of the **OSD Select Switch**. Touch data is transmitted to host while OSD menu is displayed.

Mode and Image Adjustment

Not all video controllers produce exactly the same video output levels or the same timing. The 5019T uses on-screen configuration menus to make setup and adjustment easy. The menus are selected and the menu items are adjusted using the buttons located on the front panel of the monitor. With the OSD enabled, follow the general instructions below to navigate through the adjustment menus and make adjustments.

Note

If your 5019T monitor has a stainless steel bezel, the OSD controls will be located on the back of the unit.

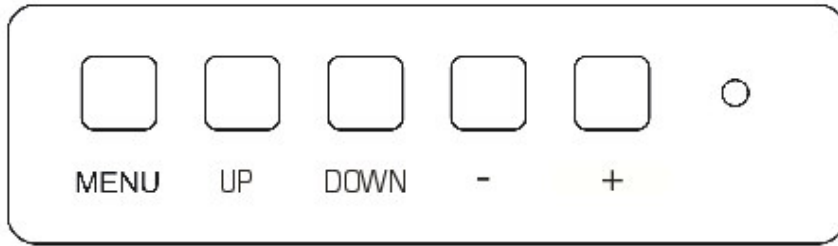

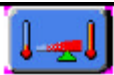
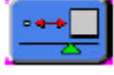

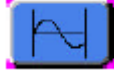
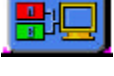









Figure 3-1. Front Panel Control Buttons

Press MENU to view the onscreen adjustment menus. Use UP, DOWN, +, or - to highlight one of the following adjustment menus:

- | | | | |
|---|-------------------------|---|--------------------|
|  | Brightness and Contrast |  | Picture in Picture |
|  | Color Temperature |  | Video Scaling |
|  | Video Adjustment |  | Language |
|  | Frequency and Phase |  | Video Source |
|  | Video System |  | Utilities |
|  | Status |  | Volume |
|  | Position |  | Exit |
|  | Rotation | | |

Press MENU to select the highlighted adjustment menu; the first adjustment option in the menu will be highlighted. Use Up or Down to navigate through the adjustment options. Use – (to move left) or + (to move right) to adjust the value of the highlighted option. Press MENU to move to the next adjustment option in the selected menu.

Press - or + to accept all changes and to return to the menu selection mode. Repeat the instructions above for selecting another adjustment menu. You

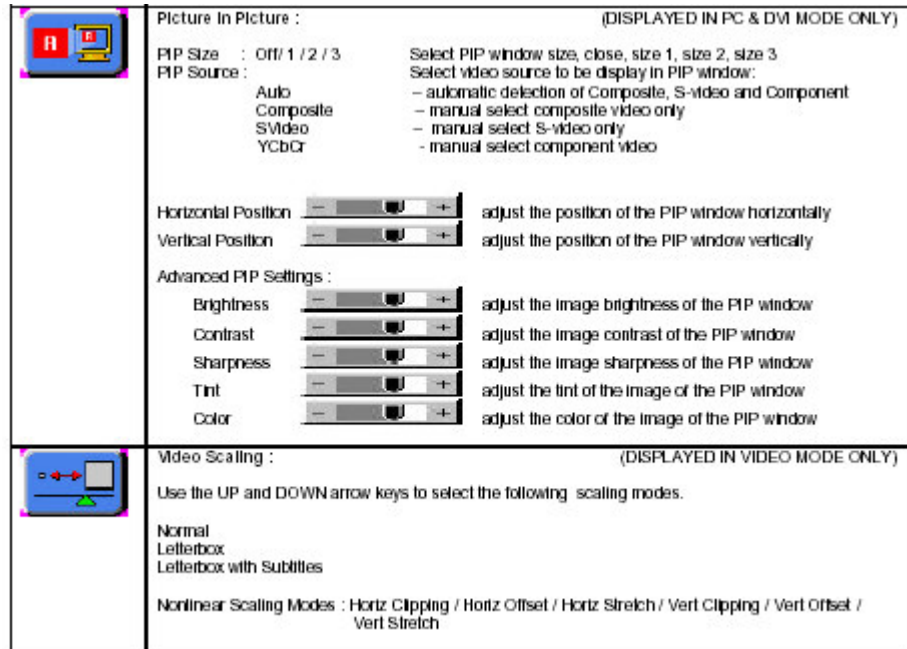

Figure 3-4. OSD Adjustment Menus (Picture in Picture, Video Scaling)

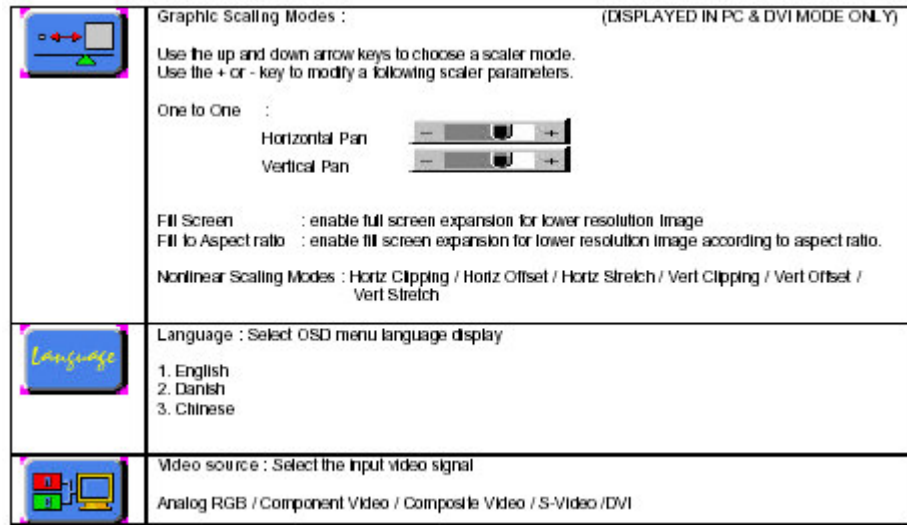

Figure 3-5. OSD Adjustment Menus (Graphic Scaling Modes, Language, Video Source)

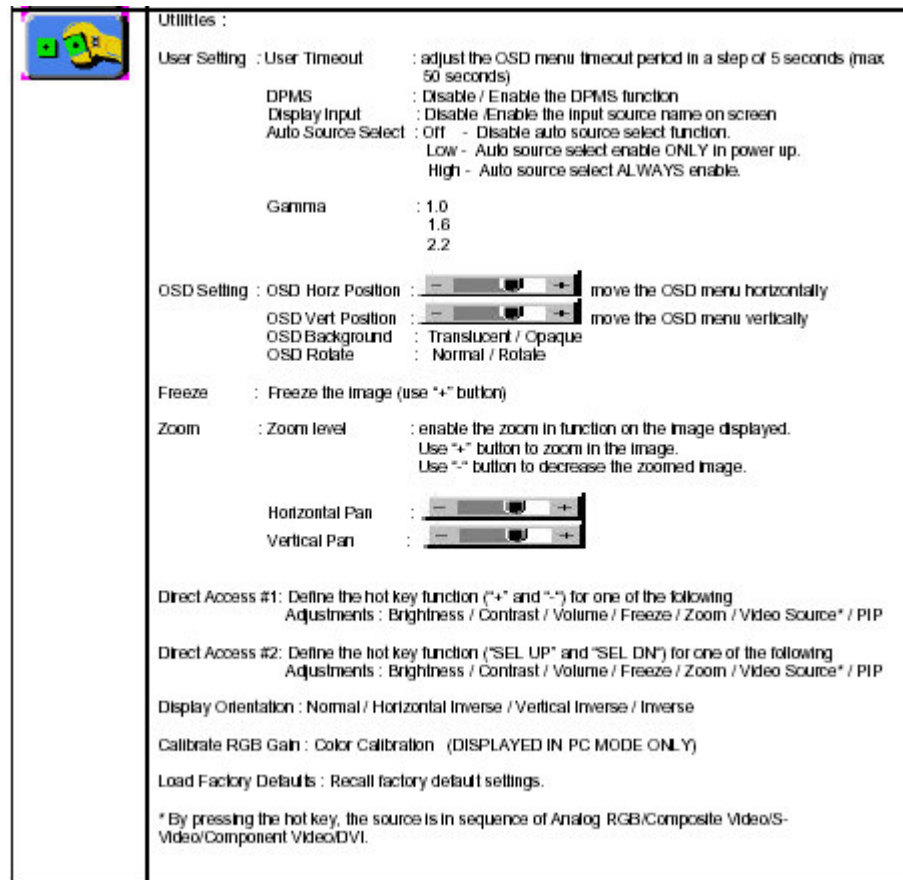

Figure 3-6. OSD Adjustment Menus (Utilities)

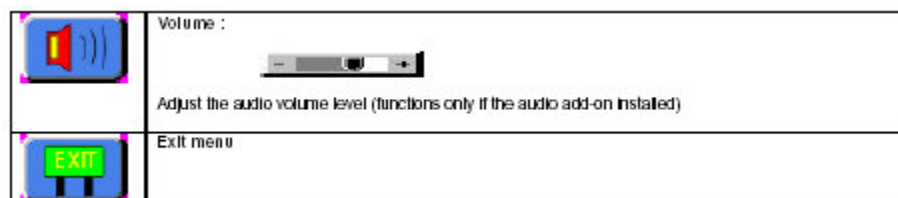



Figure 3-7. OSD Adjustment Menus (Volume, Exit Menu)

Reset Factory Default Settings

Follow these steps to reset the factory default settings for the OSD.



1. Navigate to the  menu and highlight *Load Factory Defaults*.
2. Press RIGHT (+) to choose *yes*.
3. Press RIGHT (+) again to exit the adjustment menu.
4. Press Menu again to reach the Exit Menu and press RIGHT (+). A message will appear saying that factory defaults are being restored.

Analog RGB Interface Specifications

Analog RGB interface specifications include the following :

- Based on VESA standard, separate analog RGB
- 0.7Vp-p positive true typically
- Input range: 0.5 to 1.0Vp-p typical with terminal resistance of 75Ω
- H sync signal input: TTL level, negative true or positive true
- V sync signal input: TTL level, negative true or positive true

Video Modes

The following video modes are supported on the 5019T flat panel SVGA monitor :

- 1280 x 1042
- 1024 x 768
- 800 x 600
- 640 x 480

NOTE

All video modes are non-interlaced.

If the monitor is receiving timing signals that are not compatible, [OUT OF TIMING] will appear. Follow your computer's instruction manual to set the timing so that it is compatible with the monitor.

If the monitor is not receiving any signal (synch signal), [NO SIGNAL] will appear.

Chapter 4 – Operator Input

Installing the Touch Screen Driver

Follow these steps to install the touch screen driver.

1. Insert the Xycom Automation Documentation and Support CD in the CD-ROM.
2. Navigate to the **\DRIVERS\TOUCHSCREEN\ELO.zip** file.
3. Unzip the files and run setup.exe from the folder for the operating system running on your system.

Caution

It is recommended that you keep all default settings when installing the driver.

4. When you get to the Select Controller window during the installation process, select the Elo Touch driver.
5. After driver installation is complete, the computer must be restarted. After restart, the 4-point calibration will automatically run.

The touch screen drivers are located on the Document and Support Library CD in:

\DRIVERS\TOUCHSCREEN\ELO.ZIP

Drivers can also be downloaded from <http://www.xycom.com>. Xycom Automation Technical Support can be reached at (734) 944-0482 or support@xycom.com.

Calibrating the Touch Screen

You need to calibrate the touch screen in the following cases:

- The cursor does not follow the movement of your finger or pen.
- You adjust the size of the video image or change the video mode.

To calibrate the touch screen, follow the instructions found in the applet:

START > SETTINGS > CONTROL PANEL > ELO

Note

The touch screen and controller are a matched pair calibrated at the factory. If touch screen and controllers are interchanged calibration may be needed.

Accessing the “Mouse Right Button” Functionality with the Touch Screen

Note

The Mouse Right Button functionality is supported on Windows® 2000 and Windows® XP models with either USB or RS-232 touch screens. It is also supported on Windows® 98 models with RS-232 touch screens. It is not supported on any other configurations.

Most Windows applications support use of the mouse right button, usually for context-sensitive pop-up menus. The Elo touch screen allows the user to access the mouse right button functionality via an icon that can be optionally displayed. By default, the icon is not displayed and every tap of the touch screen is interpreted as a left button. To display the icon, bring up the Elo touch controller applet:

START > SETTINGS > CONTROL PANEL > ELO

Check the “Display right mouse button” box under the “Mode” tab and press OK. The icon, in the shape of a 2-button mouse, will appear in the upper left corner of the display. The icon can be dragged to any position on the display. Normally, the left button on the icon will be shaded. Tap the right button on the icon to select the mouse right button function. The shading in the icon will switch to the right button. The next tap made on the touch screen will be interpreted as a right button click, rather than the usual left button click. The effect is only for a single tap. The touch screen switches the shading in the icon and changes back to the left button mode after that single tap.

Using a Pointing Device with a Touch Screen for DOS

The DOS mouse driver must be loaded before loading the touch screen driver if both a mouse and touch screen are to be supported. This applies only to DOS.

Chapter 5 – Hardware

The following sections outline the hardware included in your 5019T monitor.

VGA Input Connector

The VGA input connector is a D-sub connector with 15 pins.

Table 5-1. VGA Input Connector Pinout

Pin	Signal Name
1	Red
2	Green
3	Blue
4	Reserved (GND)
5	GND-Digital
6	GND-Red return
7	GND-Green return
8	GND-Blue return
9	DDC 5V
10	GND-Digital
11	Reserved (GND)
12	DDC SDA
13	Hsync
14	Vsync
15	DDC SCL

DVI-D Input Connector

The DVI-D Input Connector is a D-sub connector with 26 pins (P3).

Table 5-2. DVI-D Input Connector Pinout

Pin	Signal Name	Pin	Signal Name
1	TMDS Data 2-	2	TMDS Data 2+
3	Digital ground	4	NC
5	NC	6	DDC Clock
7	DDC Data	8	Analog Vertical Sync
9	TMDS Data 1-	10	TMDS Data 1+
11	Digital ground	12	NC
13	NC	14	+5V power supply for DDC (optional)
15	Ground (+5, Analog H/V Sync)	16	NC
17	TMDS Data 0-	18	TMDS Data 0+
19	Digital ground	20	NC
21	NC	22	Digital ground
23	TMDS Clock +	24	TMDS Clock-
25	NC	26	NC
<i>NC stands for No Connection</i>			

Composite Video and S-Video Input

The S-Video input (J1) is a min-din 4-way. The Composite Video input (j3) is through an RCA jack (yellow).

Serial Interface

The serial interface is an RS-232C. The specifications are as follows:

Data Transmission Speed: 9600 bps
 Data Length: 8 bits
 Stop Bit: 1 bit
 Parity: None

Touch Screen RS-232 Output Connector

The RS-232 output connector is a D-sub 9-pin female (CN8). The connector set screw is an inch type (4-40 UNC).

Table 5-3. Serial Signal Input Connector Pinout

PIN	Signal Name	Function
1	DCD	Data Carrier Detect
2	RX	Receive Data
3	TX	Transmit Data
4	DTR	Data Terminal Ready
5	GND	Ground
6	DSR	Data Set Ready
7	RTS	Request To Send
8	CTS	Clear To Send
9	NC	No connection

Note

Since all serial interface signals are the same on the PC side, use a straight cable to connect the 5019T to the PC.

Touch Screen USB Output Connector

The Touch screen USB output connector is a B-style female USB connector.

Table 5-4. Touch Screen USB Output Pinout

Pin	Description	Pin	Description
1	5VFUSE	3	USB+
2	USB-	4	GND

Appendix A – Technical Specifications

The following tables outline the hardware and environmental specifications for the 5019T Flat Panel Industrial Touch Monitor.

Hardware Specifications

The following table lists the hardware specifications for the 5019T.

Table A - 1. 5019T Hardware Specifications

Characteristic	Specification
Mechanical	
Height	15.70" (398.78 mm)
Width	18.51" (470.15mm)
Depth	3.00" (76.2 mm)
Mounting Depth	2.85" (72.39 mm)
Weight	21 lbs (9.52 kg)
Electrical	
AC Power	100-240 V AC, 1A, 50/60 Hz
DC Power	18-30 V DC, 2.4A maximum
Front Panel	NEMA 4/4X/12 and IP65
Agency Approvals	UL 508 Listed 1604 Listed CB EN 60950 cUL CSA-C22.2, #142 Listed CSA-C22.2, #213 Listed
Regulatory Compliance	FCC 47 CFR, Part 15, Class A ICES-003, Class A CE EMI EN55022, Class A Immunity EN 61000-6-2 Safety EN 60950 Harmonics EN 61000-3-2, Class A Flicker EN 61000-3-3

Environmental Specifications

The following table outlines the environmental specifications for the 5019T.

Table A - 2. 5019T Environmental Specifications

Characteristic	Specification
Temperature	
Operating	0° to 50° C (32° to 122° F)
Non-operating	-20° to 60° C (-4° to 140° F)
Humidity	
Operating	20% to 80% RH, non-condensing
Non-operating	20% to 80% RH, non-condensing
Vibration 5-2000 Hz	
Operating	0.006" (0.15 mm) peak to peak displacement 1.0g maximum acceleration
Non-operating	0.015" (0.38 mm) peak to peak displacement 2.5g maximum acceleration
Shock	
Operating**	15g peak acceleration, 11 msec duration
Non-operating	30g peak acceleration, 11 msec duration

** These values are with solid-state hard drives and not rotating media drives.

Appendix B – Technical Support

Xycom Automation Technical Support offers a variety of support options to answer any questions on Xycom Automation products and their implementation.

Before Contacting Technical Support

Refer to the relevant chapter(s) in your documentation for a possible solution to any problem you may have with your system. If you find it necessary to contact Technical Support for assistance, please have the following information at hand:

1. Serial number and model number.
2. The operating system type and version (i.e., Microsoft Windows NT version 4.0).
3. Exact wording of system error messages encountered.
4. Any relevant output listing from the Microsoft Diagnostic utility (MSD) or other diagnostic applications.
5. Details of attempts made to rectify the problem(s) and results.
6. The log number assigned from Xycom Automation Technical Support if this is an ongoing problem.
7. The name of the Technical Support Engineer with whom you last spoke, if known.

Contacting Technical Support

You can contact customer support through our website at <http://www.xycom.com>. This site contains the newest product datasheets, references by industrial sector, application notes, and a link to email technical support (support@xycom.com).

You can also reach Xycom Automation Technical Support by phone or fax:

Phone: 734-944-0482

Fax: 734-429-1010, Attention – Technical Support

Product Repair Program

Xycom Automation's Product Repair & Customization Department (PR&C) restores equipment to normal operating condition and implements engineering changes that enhance operating specifications. Xycom Automation tests products returned to Xycom with the standard Xycom test diagnostics.

Follow the steps below to prepare the unit for shipment:

1. Obtain a Return Merchandise Authorization (RMA) number for your unit by calling Xycom Automation, Inc. at 734-429-4971.
2. Please have the following information:
 - Company name, shipping and billing address
 - Type of service desired
 - Product repair
 - Product exchange
 - Product model number, part number, quantity, serial number(s), and warranty status
 - Failure mode and failure systems
 - Purchase order number or repair order number
3. Make sure the front panel assembly is properly attached to the unit.
4. Attach failure information to the unit to speed processing.
5. Place the unit securely in its original packaging or an equivalent heavy-duty box.
6. Mark the RMA number on your purchase order and on the outside of the box.
7. Send the unit to the address given when you receive your RMA number.

Index

- Controls
 - Front panel, 2
- Definitions
 - Hazardous Locations, 12
- Electrical Noise, 10
- Excessive Heat, 9
- Features
 - Optional, 1
 - Standard, 1
- Front panel controls, 2
- Groups, 14
- Hazardous Locations
 - Cable Connections, 14
 - Class I Locations, 12
 - Class II Locations, 13
 - Definitions, 12
 - Division 1 Locations, 13
 - Division 2 Locations, 13
 - Groups, 14
 - Installations, 11
 - Operation and Maintenance, 15
 - Power Switch, 14
 - Safety Agency Approval, 16
- I/O Panel, 3
- Interface Specifications
 - Analog RGB, 24
- Line Voltage Variation, 10
- Mounting Clips, 17
- Mounting Dimensions
 - Panel Cutout, 16
- Mounting Dimensions
 - VESA Arm, 18
- Mounting Options, 16
- OSD Switch, 19
- Pinout
 - DVI-D Input Connector, 28
 - Serial Signal Input Connector, 29
 - Touch Screen USB Output, 29
 - VGA Input Connector, 27
- Power Management, 8
- Power Terminal Block, 9
- Repairs and Service, 33
- Returning a Unit, 33
- Safety Agency Approval, 16
- Service and Repairs, 33
- System Power, 8
- Technical Specifications
 - Environmental, 31
 - Hardware, 30
- Touch Screen
 - Calibrating, 25
 - Driver Installation, 25
 - Using a Mouse, 26
 - Using a Pointing Device, 26
- Video Modes, 24

143627(A)

Xycom Automation, Inc.
734-429-4971
Fax: 734-429-1010
<http://www.xycom.com>

Canada Sales: 905-607-3400
Northern Europe Sales: +44-1604-790-767
Southern Europe Sales: +39-011-770-53-11

XYCOM[™]
AUTOMATION
Open the PossibilitiesSM